

# ELECTRO-HÆMOSTASIS IN OPERATIVE SURGERY

BY

ALEXANDER J. C. SKENE, M. D., LL. D.

Professor of Gynecology in the Long Island College Hospital, Brooklyn, N. Y.; formerly Professor of Gynecology in the New York Post-Graduate Medical School; Gynecologist to the Long Island College Hospital; President of the American Gynecological Society, 1887; Corresponding Member of the British, Boston, and Detroit Gynecological Societies, of the Royal Society of Medical and Natural Sciences of Brussels, of the Obstetrical and Gynecological Society of Paris, and of the Leipzig Obstetrical Society; Honorary Member of the Edinburgh Obstetrical Society; Fellow of the New York Academy of Medicine; ex-President of the Medical Society of the County of Kings; ex-President of the New York Obstetrical Society

LAM LIBRARY

NEW YORK  
D. APPLETON AND COMPANY

1899

K 1

M68  
S62  
1899

TO  
JOHN BYRNE, M. D., LL. D., M. R. C. S. E.,  
AS AN ACKNOWLEDGMENT OF HIS  
ORIGINAL AND MOST VALUABLE CONTRIBUTIONS TO  
THE SCIENCE AND ART OF THE ELECTRIC CAUTERY IN SURGERY;  
HIS SUPREME PROFESSIONAL HONOR, HONESTY, AND COURTESY;  
AND IN PERSONAL GRATITUDE FOR  
HIS TRUE AND CONSTANT FRIENDSHIP,  
THESE PAGES ARE INSCRIBED BY  
THE AUTHOR.

## P R E F A C E

---

THIS contribution relating to electro-hæmostasis and the electric cautery in general and special surgery, is issued to supplement the third edition of my work on diseases of women, in which the subject was referred to, but altogether too briefly discussed.

The interest manifested by the profession in this subject, the employment of the new methods of operating in other than gynæcological surgery, a number of recent improvements in instruments and in the technique of operating, and a larger experience confirmatory of the value of the principles and practice advocated, both prompted the undertaking and raise the hope that the results will be acceptable to the profession.

The part of the work devoted to electro-hæmostasis may appear to be rather aggressive, not to say revolutionary, and therefore it might be judicious to give in this preface a statement explanatory of the principles involved and a preliminary argument in their favor; but past experiences remind me that it is unnecessary to do so.

In former contributions to medical literature I have avoided all declamations and special pleadings regarding the merits of that which I had to offer, in order that I should have the opinion of the profession to guide me to rational conclusions regarding the value of my work.

Having fared well in the past, I am perfectly satisfied to leave the present effort to the judgment of those for whom these pages were written—the thinking, reading, working members of the medical profession.

My grateful acknowledgments are due to Dr. R. L. Dickinson for taking charge of the illustrations, which speak for themselves; to Dr. W. H. Seymour for his valuable laboratory work and demonstrations of the process of electro-hæmostasis; and to Louis M. Pignolet, the maker of the electrical instruments.

## CONTENTS

CHAPTER	PAGE
I.—INTRODUCTION . . . . .	1
II.—DESCRIPTION OF INSTRUMENTS . . . . .	9
III.—RESULTS OF THIS HÆMOSTATIC PROCESS . . . . .	21
IV.—ELECTRO-HÆMOSTASIS IN OVARIOTOMY . . . . .	30
V.—ELECTRO-HÆMOSTASIS IN MYOMECTOMY AND ABDOMINAL HYSTERECTOMY	39
VI.—ELECTRO-HÆMOSTASIS IN OVARIO-SALPINGECTOMY . . . . .	49
VII.—ELECTRO-HÆMOSTASIS IN APPENDECTOMY . . . . .	57
VIII.—TREATMENT OF CANCER OF THE UTERUS BY THE ELECTRO-CAUTERY AND HÆMOSTASIS . . . . .	65
IX.—THE ELECTRO-CAUTERY IN THE TREATMENT OF PELVIC ABSCESS AND DISEASES OF THE VULVA AND VAGINA . . . . .	85
X.—ELECTRO-HÆMOSTASIS IN EXTIRPATION OF THE MAMMARY AND LYM- PHATIC GLANDS . . . . .	95
XI.—ELECTRO-HÆMOSTASIS IN EXTIRPATION OF TUMORS OF THE BLADDER .	102
XII.—THE ELECTRO-CAUTERY IN THE TREATMENT OF URETHRAL AFFECTIONS .	113
XIII.—ELECTRO-HÆMOSTASIS IN THE TREATMENT OF RECTAL HÆMORRHOIDS .	120
XIV.—THE TREATMENT OF NEOPLASMS OF THE SKIN AND MUCOUS MEMBRANES WITH THE ELECTRO-CAUTERY AND ELECTROLYSIS . . . . .	129
XV.—ASEPSIS AND ANTISEPSIS IN SURGERY . . . . .	136
XVI.—ASEPSIS AND ANTISEPSIS (CONTINUED) . . . . .	156

## LIST OF ILLUSTRATIONS

NO.	PAGE
1. Electro-hæmostatic forceps . . . . .	9
2. Electro-hæmostatic forceps chamber . . . . .	10
3. Electro-hæmostatic forceps chamber . . . . .	10
4. Transformer . . . . .	11
5. Flexible cable . . . . .	12
6. Portable storage battery . . . . .	14
7. Use of alternating street current . . . . .	15
8. Use of continuous street current . . . . .	16
9. Portable battery with ampèremeter . . . . .	17
10. Artery, treatment of . . . . .	19
11. Artery, macroscopic appearance . . . . .	21
12. Artery, macroscopic appearance . . . . .	22
13. Artery, macroscopic appearance . . . . .	22
14. Artery, microscopic appearance . . . . .	24
15. Artery, microscopic appearance . . . . .	24
16. Fallopian tube, macroscopic appearance . . . . .	26
17. Fallopian tube, macroscopic appearance . . . . .	27
18. Omental adhesions . . . . .	31
19. Artery forceps . . . . .	32
20. The dome . . . . .	32
21. Visceral protection during treatment . . . . .	33
22. Intestinal adhesion . . . . .	34
23. Shield forceps for laparotomy . . . . .	35
24. Small pedicle forceps for ovariectomy . . . . .	35
25. Large pedicle forceps . . . . .	36
26. Pedicle, treatment . . . . .	37
27. Pedicle of fibroid, treatment . . . . .	39
28. Sessile fibroid, incisions . . . . .	40
29. Sessile fibroid, cuff of peritoneum . . . . .	40
30. Dome controlling hæmorrhages . . . . .	41
31. Steps in treating stump in myomectomy . . . . .	42
32. Treatment of broad ligament . . . . .	43
33. Treatment of broad ligament . . . . .	44
34. Final treatment of vessels . . . . .	45
35. Use of dome in sac of Douglas . . . . .	47
36. Removing tube and ovary . . . . .	54
37. Removing tube and ovary . . . . .	55
38. Seizure in appendectomy . . . . .	61
39. Treatment of mesentery . . . . .	62

NO.	PAGE
40. Second seizure in appendectomy . . . . .	63
41. Stump after appendectomy . . . . .	63
42. Epithelioma of cervix . . . . .	66
43. Epithelioma of cervix . . . . .	66
44. Byrne's speculum . . . . .	67
45. Byrne's speculum in position . . . . .	68
46. Byrne's cautery loop . . . . .	69
47. Byrne's special loop carrier . . . . .	70
48. Passing loop around tumor . . . . .	71
49. Diverging volsellum . . . . .	72
50. Cautery knife . . . . .	72
51. High amputation of cervix . . . . .	73
52. High amputation of cervix . . . . .	73
53. High amputation of cervix . . . . .	74
54. Cervix excised . . . . .	75
55. Dome electrode . . . . .	75
56. High amputation of cervix . . . . .	76
57. Stump after removal of cervix . . . . .	77
58. Cautery incision in vagina . . . . .	77
59. Elytrotomy . . . . .	78
60. Hysterectomy, treating broad ligament . . . . .	79
61. Diagram of seizures in hysterectomy . . . . .	79
62. Shield forceps for vagina . . . . .	80
63. Hysterectomy, treating broad ligament . . . . .	80
64. Hysterectomy, treating ovary and tube . . . . .	81
65. Peritoneal sutures . . . . .	82
66. Peritoneal sutures tied . . . . .	83
67. Pedunculated tumor of bladder . . . . .	105
68. Protecting bladder wall . . . . .	106
69. Treating urethral gland . . . . .	116
70. Treating urethral gland . . . . .	117
71. Hæmorrhoidal clamp . . . . .	121
72. Operation for hæmorrhoids . . . . .	122
73. Operation for hæmorrhoids . . . . .	123
74. Dickinson's oblique seizure of hæmorrhoids . . . . .	124
75. Treating fissura in ano . . . . .	127
76. Ordinary window frame . . . . .	144
77. Improved window frame . . . . .	145
78. Ordinary door frame . . . . .	146
79. Improved door frame . . . . .	147
80. Improved door frame with wood trimming . . . . .	148
Plate I—Reorganization of stump . . . . .	<i>facing</i> 26
Plate II—Reorganization of stump . . . . .	28

# ELECTRO-HÆMOSTASIS IN OPERATIVE SURGERY

---

## CHAPTER I

### INTRODUCTION

IN looking backward upon the evolution of surgical hæmostasis, one of the most agreeably surprising steps observed in the progress toward the ideal is the discovery that an aseptic ligature can be inclosed in the tissues without disturbing the healing process. Catgut ligatures, properly prepared and sterilized, soon answered all the requirements of the surgeon in so many operations that he has been disposed since then to rest satisfied in the belief that the ideal method had been attained, so vastly superior was the new way to the old. Even at the present time one is liable to be considered hypercritical and fastidious if he questions the utility and competence of the surgery of the day in controlling hæmorrhage in incised wounds. Nevertheless, the modern ligature has its defects and failings when employed in certain operations and in some conditions.

Some of those who first used catgut as a ligature acknowledge that it is difficult to sterilize and keep perfectly clean, and that it is not altogether reliable in ligating blood vessels in the pedicle of an ovarian tumor, for example. More recently it has been discovered that it is objectionable in wounds which are septic or contain necrotic tissue. Take, for example, a suppurating ovarian tumor or a pyosalpinx: the broad-ligament pedicle is nearly always sep-



tic, and no matter how clean the ligature may be when applied it soon becomes contaminated by contact with the diseased tissue, and, being dead animal tissue, it adds of its own self to the field for the culture of bacteria. A ligature thus contaminated is not absorbed, but acts as a foreign body for the promotion of evil and the interruption of the process of repair, and is responsible for the bad results which have sometimes followed when I had operated according to all the rules of modern surgery. Others have had similar failures from the same cause, if I may judge from cases which have come to my notice. On this account catgut is the worst material that can be left in a wound which is not perfectly free from germs of disease. Of minor importance, but still worthy of notice, is the fact that dry catgut is not very flexible and easily handled, and if softened by immersion in a sterilized or antiseptic solution it stretches or breaks, and can not be depended upon to close vessels and hold them. This tendency to stretch is increased by the softening which takes place while the ligature is in the tissues, and therefore hæmorrhage may occur. This has happened in abdominal operations, and on that account many operators, even in the early days of modern surgery, preferred silk ligatures for much of their work.

If I mistake not, the majority of surgeons at the present time use silk ligatures in ovariectomy, hysterectomy, and similar operations; and yet the silk ligature does not meet all the demands of surgery. The objectionable features of silk are, that it is not absorbed but remains in the tissues where it is placed, quiescent in many cases, but occasionally causing much mischief. The unfavorable behavior of the silk ligature has been so fully recognized by some of the leading surgeons that they have raised the question whether this non-absorbable ligature should ever be used in abdominal surgery. Judging from my own limited observations and the meager records found in surgical literature on this subject, it appears that silk ligatures either become encysted and remain where they are placed, or,

becoming freed from the protecting exudate, wander about until they are thrown out by the eliminative process of suppurative or ulcerative inflammation.

Fine ligatures of silk applied to small blood vessels in areolar and muscular tissue become walled in with reparative exudates and may remain indefinitely, but those used in abdominal operations are likely to work their way out through the skin or escape into some neighboring viscus. Under favorable circumstances the harmful action of silk ligatures has escaped observation, owing to the fact that they cause no trouble until long after recovery from the operation in which they were employed. If the silk is clean when used, no immediate disturbance of the process of healing is caused, and so far silk appears to be a perfect agent; still, it is not so, for the necessary walling in of a silk ligature requires more time than the disposal of an absorbable ligature, and the quantity of new material left in the wound surrounding the ligatures retards the process of repair. On this account the tissues in the neighborhood of the wound remain indurated, and do not regain their elasticity and freedom from tenderness for a long time, even when union takes place promptly and without suppuration.

These facts regarding the slow recovery or repair caused by the presence of silk in the tissue, and the disposition of such ligatures to be thrown out in course of time, are illustrated in an extirpation of the mammary gland which occurred in my practice. The patient being spare of habit and to a slight degree hæmorrhagic, more ligatures were required than usual, and all of the fine silk on hand was used up, and so one ligature of thick silk had to be used. Healing took place without delay, but the tissues remained indurated and irregular, and fixed to the wall of the thorax for a long time. There were also slight pains at times and tenderness. Two years afterward the patient returned for advice regarding an inflamed part about an inch in diameter, presenting all the signs of a small abscess, situated about an inch and a half from the original incision. The parts were

incised and a mass of exudate or scar tissue removed with a curette. In this mass I found the large ligature which I had used in operating. The silk was in a state of good preservation, and only the short ends of the ligature protruded from the mass in which the ligature was imbedded. The patient rapidly recovered, and there was no return of the cancer one year and a half afterward. This shows that the whole trouble came from the ligature and not from the recurrence of the disease.

Were this all of the evil that can be charged fairly against the silk ligature one might rest satisfied, but worse follows the use of ligatures of all kinds in abdominal and pelvic surgery. Ligatures applied to the broad-ligament pedicles of ovarian tumors and Fallopian tubes are guilty of much wrong-doing. For example, unless the conditions are unusually favorable, the pedicle of an ovarian tumor can not be tied tightly enough to close the arteries in the way that surgeons say they should be ligated to make sure of controlling hæmorrhage with certainty. There is a liability, in thick pedicles, for the tissues to shrink under the pressure of the ligature and permit the vessels that have been temporarily closed to open again and allow bleeding to take place. This inefficiency of the silk ligature has been observed by Dr. Howard A. Kelly, so that he has adopted the method of ligating the pedicle in two sections, by including the ovarian arteries in one ligature and the tubal and uterine side of the pedicle in the other, and in addition to that he also ligates the larger vessels in the end of the stump.

Whenever the tissues of the pedicle are rendered friable by disease or degeneration, it is well-nigh impossible to control hæmorrhage with a ligature of any kind. Silk is as bad as or worse than anything else, for it cuts the tissues if tied as tight as possible without breaking.

These are some of the charges which can be brought fairly against the silk ligature as a means of immediately and permanently arresting hæmorrhage. The subsequent

behavior of the ligature, and the character of the stump to be repaired after ligation, are still more unsatisfactory to both the patient and the surgeon. The pressure of the ligature upon the nerve tissue and the traction of the parts toward the point of constriction, especially in a short, broad pedicle, cause irritation and pain. There is a large mass of tissue projecting beyond the ligature which has to be disposed of by a process of degeneration and absorption; the ligature and the tissue of the pedicle beneath it have to be closed in by a deposit of plastic material, which in time is disposed of by absorption, and the ligature set free. During all these weeks or months required to completely repair the stump there is oftentimes considerable pain and distress in the site; nothing dangerous or alarming but annoying. Not infrequently when a diseased Fallopian tube forms part of the pedicle there is a secondary attack, maybe several, of inflammation in the stump, caused by the tube remaining open and giving out septic material. These sequelæ have passed unnoticed by many surgeons, and are lightly spoken of by others, presumably because there was no danger to the life of such patients; but the best operators have given attention to the subject, and, having watched their results with scientific accuracy, have observed these results and recorded them.

What becomes of silk ligatures that are left in the peritoneal cavity is a question of vast importance. One opinion which for a long time prevailed was that a silk ligature applied to a broad-ligament pedicle becomes encysted and remains quiescent for all time. Exceptions to this rule were admitted, and were accounted for by some unclean operating or a septic ligature that caused suppurative inflammation in the stump by which the ligature was set free or found its way into some neighboring viscus. This is almost altogether incorrect. Occasionally it may happen that a ligature becomes firmly fixed to the broad ligament by an exudate and remains imbedded for all time, but that, I believe, is the exception, not the rule.

This very interesting question of the disposal of silk ligatures, as a rule, has not yet been answered fully, so far as I can ascertain. Guided by my own experience, I believe, as already stated, that ligatures left in the peritoneal cavity are at first encysted and finally liberated, and remain in the peritoneum or escape through some of the viscera or the abdominal wall. So many cases of this kind have been reported that I need say nothing on that subject, except that they make their exits by being first set free from the plastic stuff that surrounds them and travel outward by a process of ulceration or suppuration and necrosis of the tissues in the way of their outgoing. At least that is the way of it according to my own observations.

By way of illustrating what has been said about ligatures being set free in the peritoneal cavity, I give the history of a specimen brought to my clinic at the New York Post-Graduate School by Prof. F. Ferguson. The patient from whom the specimen was obtained died of some thoracic disease, and while making the autopsy Professor Ferguson learned that she had had her ovaries and tubes removed about one year prior to her death. The pelvic organs were removed entire, and I had every facility for their examination. The stumps were rounded off even with the posterior surface of the broad ligaments, showing that all that portion of the stumps outside of the ligature had been disposed of, and also the exudate that had been thrown around the ligatures to inclose them. The ends of the tubes were open. The ligatures of thick silk were found in the most dependent part of the sac of Douglas, quite free from, but resting upon, the thickened peritoneum. The thickening of the peritoneum in the sac resulted from cellular proliferation and exudation, possibly brought about by irritation arising from the presence of the ligatures. What would have become of the ligature finally, if the patient had lived, I know not.

From among a number of cases recorded in which the ligature migrated I give the following: The patient had

a severe puerperal peritonitis followed by chronic ovaritis and varicose veins of the broad ligaments. This, with very extensive old adhesions of all the pelvic organs, caused so much suffering that it became necessary to operate. The tubes and ovaries were removed, the veins closed, and adhesions separated. One ovary and tube were found high up and held in this abnormal position by adhesions. When these were ligated and removed the stump rested near the lower part of the wound in the abdominal wall. The recovery was quite favorable, but about two months after the patient was dismissed she returned, complaining of pain in the scar near its lower end. The scar at that point was stretched, and there was a slight protrusion, not unlike a beginning hernia, but there was some fluctuation and flatness on percussion, which led to a diagnosis of abscess. An opening was made and a small amount of serum and tissue *débris* escaped, but not any visible pus. The sinus was washed out, but it would not close. A little serous discharge continued for six weeks or two months, when she returned for treatment. Suspecting the presence of a ligature that had escaped from its environing exudate, it was fished out with a blunt hook, and then healing soon closed the sinus.

Having observed these disappointing actions of ligatures, I naturally looked for something better in surgical hæmostasis. This I found in the work of Dr. Thomas Keith, who taught me his method of treating the pedicle in ovariectomy by the clamp and cautery, which in theory and practice was most satisfactory. No doubt this feature of his operating contributed largely to making him the most successful ovariectomist of his time. The experience of years and a large number of operations in which his method was used has fully confirmed my confidence in this way of controlling hæmorrhage. The method of treating the pedicle of ovarian tumors employed by Keith and his followers was never adopted by surgeons in general. This was due, apparently, in part, to ignorance of the principles of the method, but more especially to the difficulties in the

technique of the procedure. Many believed, and still believe, that it was necessary to char the stump with the cautery in order to stop the bleeding; but the fact is, Keith applied a clamp with broad jaws to the pedicle and compressed it strongly, and then applied a large cautery iron to the upper side of the clamp until the instrument was heated sufficiently to desiccate the tissues and not to char them. This required much time and large experience in handling the cautery iron, in order to obtain the degree of heat necessary and to know the length of time it should be applied. In other words, to treat a broad-ligament pedicle in this way required a knowledge and judgment that but few had the patience to acquire.

I confess that I was not sure of my work in my first operations, and sometimes applied a light ligature to feel safe before I dared return the stump into the abdominal cavity. When ovariectomy became improved, so that better results were obtained, and material for ligatures was made aseptic and more appropriate, I gave up the clamp and cautery and used the ligature; but I was never satisfied with the results, and earnestly sought to overcome the objection to the clamp and heat to control hæmorrhage—namely, the application of the heat supply. While thinking of how to overcome these difficulties, my attention was called to the use of electricity in heating laundry smoothing irons. It then occurred to me to adapt the same heating power to surgical instruments, such as the clamp and forceps.

My requirements in this regard were explained to Mr. Louis M. Pignolet, an electrician, who has given much attention to electricity as used in medicine and surgery. He at once took up the study of the subject with enthusiasm, and soon produced the instruments and appliances required. He first made an artery forceps, then a clamp, and finally a full set of hæmostatic instruments. I should say that it was his adaptation of the system of electric heating to these instruments, which enabled me to employ the method for the control of bleeding in all surgical operations.



## CHAPTER II

### DESCRIPTION OF INSTRUMENTS

THE following description of the instruments is given by Mr. Pignolet.

In these forceps the heat is generated by the passage of an electric current through a resistance wire in a chamber in one of the jaws, for it has been found to be sufficient to heat but one of them.

The method of heating is simple, and is applicable to forceps of various forms and sizes since the mechanism of the instrument is not altered by the electrical attachments. The construction is shown by the illustrations, of

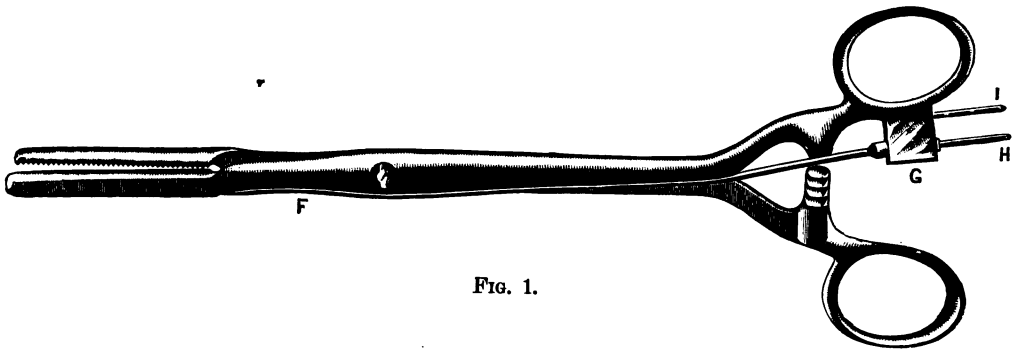

FIG. 1.

which Fig. 1 is a side view of a compression forceps heated on this principle. Fig. 2 is a longitudinal section, and Fig. 3 a top view of the heated jaw on an enlarged scale, with the cover *D* and the insulating material *C* removed.

A resistance wire, *A*, is located at the bottom of the chamber, close to the face of the jaw, from which it is



insulated by a thin layer, *B*, of fireproof material. The chamber above the wire is filled with an electrical insulator, *C*, which is also a non-conductor of heat, such as asbestos, and is closed water-tight by the sheet-metal cover *D*. One end of the resistance wire is connected to the jaw, and the other to an insulated copper wire, *E*, placed in a metal tube, *F*, which extends from the chamber to the metal block, *G*, attached to the handle of the forceps.



FIG. 2.

Here the copper wire is connected to an insulated terminal, *H*, mounted in the block. A similar terminal, *I*, is attached directly to the block and is uninsulated. By this method of construction the electrical wires are incased in metal, so that the forceps can be sterilized and handled without injury, the same as an ordinary instrument. Starting at the insulated terminal, the path of the current is through the copper wire and the resistance wire to the tip of the jaw, thence through the blade of the forceps to the uninsulated terminal. The copper wire and the blade of the forceps form a path of good electrical conductivity, and are consequently but very slightly heated by the passage of the current used. On the other hand, the wire in the chamber is a poor conductor, and is heated to a greater or less degree according to its resistance and the strength of the current.

The electrical energy required to heat the forceps varies from ten to thirty-five watts, according to the size of the instrument, and is less than that required by the ordinary cautery electrodes. A storage or primary battery that will heat the electrodes will generally answer for the forceps; but, as all batteries require care to keep them in working order, the use of the electric light or power current from a dynamo is preferable wherever it is available.



FIG. 3.

The dynamo current can be used through a controlling rheostat, or, if the current be alternating, through a transformer capable of furnishing a low voltage current of various strengths and pressures to suit the different forceps. A special advantage of the transformer is that the current for use is of very low pressure, and is generated in an insulated coil of wire by the inductive action of the dynamo current which flows through an adjacent coil. If the wires or connections be accidentally touched, nothing is felt on account of the low pressure of the transformer current, but with a rheostat under similar conditions a disagreeable shock might be experienced. Furthermore, the insulation

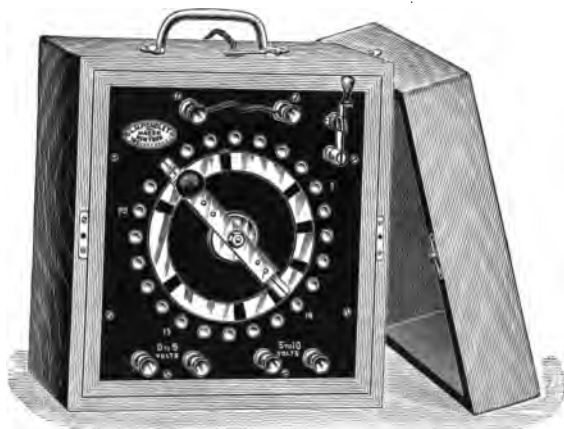

FIG. 4.

between the two coils prevents leakage of the high-pressure current to the low-pressure circuit, so that freedom from shocks is insured. If the dynamo current be continuous, the transformer can be used by converting the continuous into an alternating current, by means of a small rotary transformer.

An efficient and convenient type of transformer is represented by Fig. 4. It will furnish current for heating the forceps, and for all sizes of cautery electrodes, as well as for lighting small incandescent lamps. The pressure and quantity of the current is increased by moving the switch

arm to the right from one contact button to the next until the proper amount is obtained. By noting the contact at which the desired heat is developed for a particular forceps, the switch may be set at that point, and the forceps used with the certainty that the heat will be suitable.

As shown by Fig. 5, one end of the flexible cable for conveying the electric current to the forceps is inclosed in

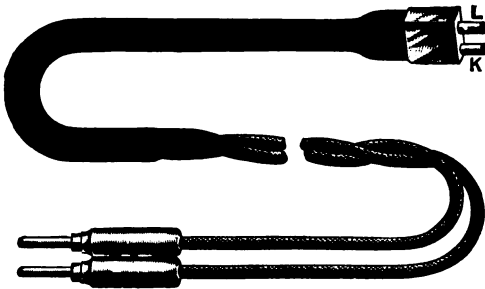

FIG. 5.

a soft-rubber tube, and is provided with two hollow metal sleeves, *L K*, which are mounted in a piece of insulating material, and are adapted to slip over the two terminals, *I H*, of the forceps.

Each sleeve is insulated from the other, and is connected with one of the two conductors composing the flexible cable.

#### DIRECTIONS FOR USING THE ELECTRICAL FORCEPS.

The method of arresting hæmorrhage with these forceps consists in firmly compressing a portion of the bleeding tissues or the end of a vessel between the jaws of the instrument, in order to expel as much of the moisture as possible, and then desiccating the compressed tissues by heat generated in the jaws by the electric current. In this way the walls of the arteries become united and hæmorrhage is effectually prevented. The temperature required for desiccation is from 180° to 190° F., which is not high enough to char or burn the tissues, but simply to desiccate or cook them.

The forceps are sterilized in the same manner as the ordinary instruments, but after removal from the sterilizer it is not advisable to place them immediately into cold water, while they are hot, as the contraction of the heated

air inside may eventually cause water to enter at the insulated terminals. After sterilizing, a little sterilized vaseline, or similar preparation, is rubbed over the inner faces of the jaws of the forceps to cover them with a thin film, which will prevent the tissues from adhering to the instrument. The rubber-covered end of the electrical cable is sterilized in boiling water and afterward wrapped in a sterilized towel or immersed in an antiseptic solution—such as a five-per-cent carbolic solution—until needed. Bichloride of mercury should not be used, as it attacks the metal sleeves at the end of the cable.

In applying the forceps, all the tissues to be treated should be firmly compressed between the heated jaws of the instrument, for if a portion extend beyond, a second application will be necessary. Before the electric current is turned on, a piece of gauze or a shield is applied where needed between the forceps and the adjacent tissues to protect them from injury by contact with the hot instrument. Tissues which do not touch the jaws require no protection.

The two connector sleeves at the end of the flexible cable are then slipped over the two terminals on the end of the forceps and pushed firmly into place to make a good electrical connection. If the electric current has been previously turned on, the putting of the connector sleeves into place completes the circuit and establishes the current; but if this has not been done, the current is now turned on.

The method of connecting the forceps to the battery or transformer, which may be used as a source of electricity, is plainly shown by Figs. 6, 7, 8, and 9, so that no explanation is needed. The current required to properly heat the forceps is noted for each one made. Therefore, it can be regulated to suit the forceps from the indications of an ampèremeter included in the circuit to measure the strength of the current. This is the best way; but if no ampèremeter be convenient, experiments upon a piece of

raw meat will enable one to regulate the current to suit the forceps, so that desiccation is obtained in the proper time. Experience will enable the operator to tell if the



FIG. 6.—Forceps heated by the electric current from a storage battery.

temperature be right by touching the forceps from time to time; this can be done without pain as the heat is concentrated upon the inner surfaces of the jaws, and the other parts of the instrument are not as hot. One setting of a transformer or of the rheostat of a storage battery will be sufficient, if the same adjustment be made in subsequent operations; but the battery should not be used when its charge is nearly exhausted, if uniform results are desired, unless an ampèremeter be employed. For the same reason, the transformer should be fed by an electric-light current, as this has an almost constant pressure, and not by one used exclusively for power, as such a current is subject to considerable changes of pressure. An ampèremeter should be used with the ordinary primary battery for the polarization, as the varying strength of the exciting fluid prevents it from being adjusted so as to furnish a current of uniform strength.

Before removing the forceps, the tissues projecting beyond its jaws are cut off, which may in some cases be done while the heat is being applied, in order to save time. There being danger of losing sight of the stump by its dropping back into the abdominal cavity, as for example may happen in ovariectomy, the tissues on the under side of the jaws should be grasped by a shield or compression forceps to hold the stump in place for inspection. The electrical forceps is then carefully opened far enough to allow the desiccated stump to slide out from between the jaws in the direction of the teeth. Care in this is important, for if the tissues should adhere to the instrument, which may happen if vaseline be omitted, they might be torn apart and a ragged stump be left.

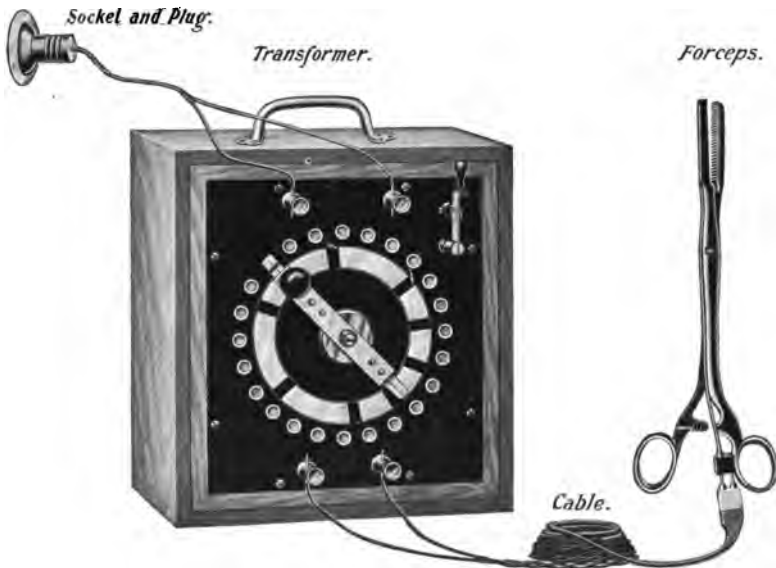

FIG. 7.—A transformer connected by a cable and plug to an incandescent lamp socket on an alternating electric-light circuit, and heating a forceps by the low-pressure current generated in its secondary.

Before using the forceps for the first time, it is instructive to experiment with them on a piece of raw meat, so as to become familiar with their action, as well as to ascer-

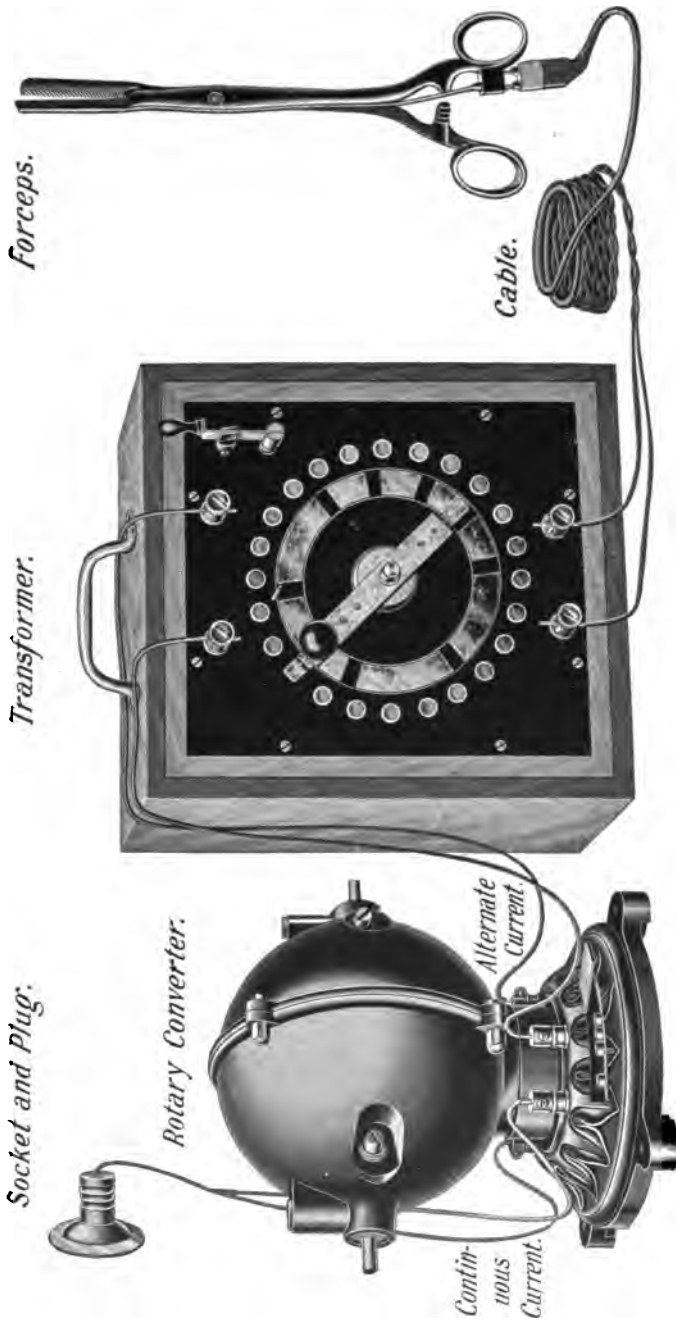

FIG. 8.—Method of heating the forceps by means of a transformer when the electric-light current is continuous. The rotary converter connected to the electric-light circuit converts the continuous current into an alternating current suitable for operating the transformer.



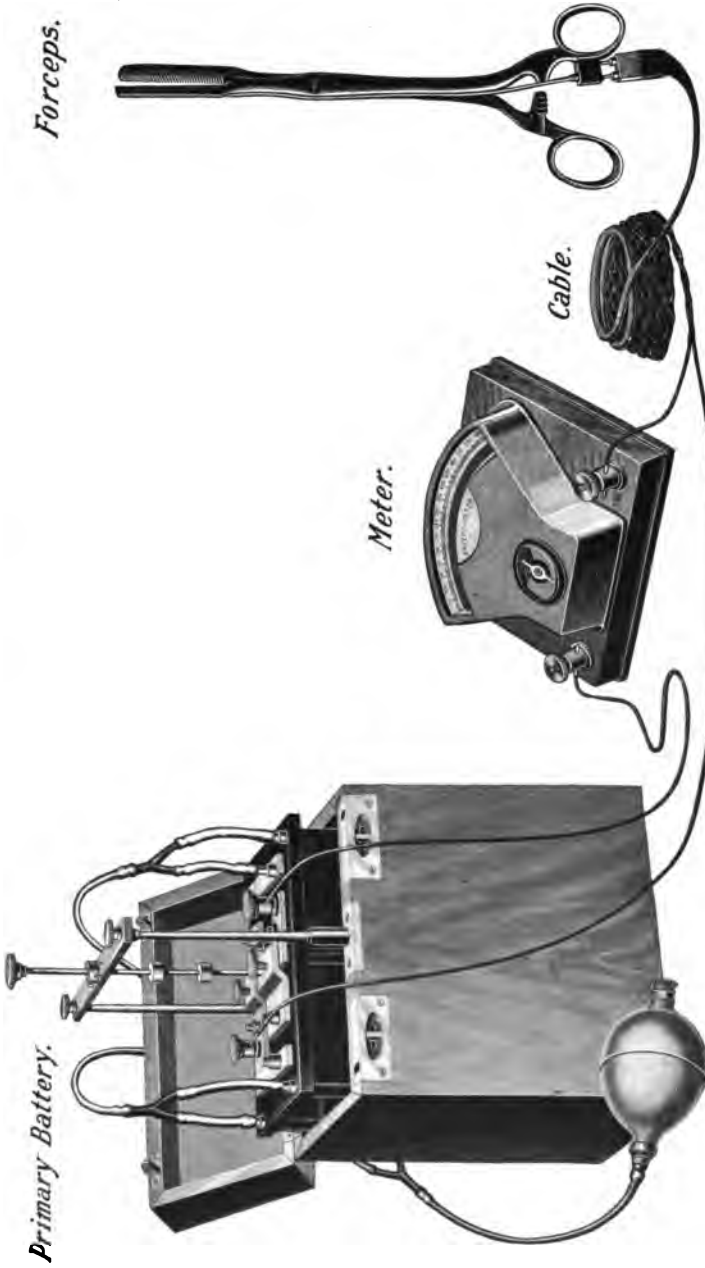

FIG. 9.—Forceps heated by a primary battery, an ampèremeter being included in the circuit to measure the strength of the current.



tain whether the source of electricity is suitable and can be properly controlled.

Absence of bleeding upon the removal of the forceps shows that the desiccation has been effective, and the stump can be left without fear of secondary hæmorrhage. The occurrence of bleeding immediately upon the removal of the forceps indicates that the desiccation has been insufficient, or that some of the tissues have escaped the grasp of the forceps. In this event, reapply the forceps to the stump and repeat the heating, giving about ten per cent more current, or continuing the heat for a longer time if the bleeding has been due to insufficient desiccation.

The time required for desiccation varies from a half to two minutes, according to the thickness of the compressed tissues or size of the arteries, two minutes being required for the ordinary ovarian pedicle and the broad ligament. If desired, or if the tissues be very thick, the current can be continued for three or four minutes, or even longer without danger, on account of the low temperature. When the time of application has expired, the current can be shut off by a switch or by removing the connector from the forceps. The desiccation can be hastened by starting with more than the usual current, and continuing the greater current for about a third of the time of application. For example, if the current necessary to properly heat the forceps is ten ampères and the time of application is two minutes, give twelve ampères for about forty seconds, then decrease to ten ampères for the rest of the time. It is well to commence with the forceps closed on the first notch of the lock, and after the heat has been applied for about half a minute and the tissues have begun to shrink to close the instrument fully. In this way the greatest possible compression of tissues is obtained.

In the treatment of isolated arteries the end of the vessel is grasped by a tenaculum, and the electric artery

forceps applied crosswise, or the artery is seized by the electric forceps in the same manner as with an ordinary artery forceps when a ligature is to be used. Isolated arteries, or those inclosed in a mass of tissue, when treated by this method are so thoroughly and completely closed that they can not be opened up again either by blood pressure or the most critical dissection. This has been clearly observed and fully demonstrated both clinically and by laboratory experiments.

The end of an artery or the stump of a pedicle when thus treated resembles parchment in gross appearance. The thickness depends upon the size of the vessel or mass of tissue treated. A large uterine artery is reduced to about a line in thickness, and an ordinary broad-ligament pedicle to less than an eighth of an inch in thickness. See Fig. 10. The part is translucent and structureless, and thus enables the surgeon to tell at a glance when the treatment is incomplete, by observing the vessels that remain unclosed; he knows then that the pressure and heat should be reapplied to complete the hæmostasis.



FIG. 10.—An artery from fresh beef closed solidly by author's method in half a minute. Seen in perspective and in section. Life size.

Occasionally in treating a thick mass of tissue the central portion of it becomes heated before being fully compressed, and the blood is coagulated in the vessels and leaves dark strips or general staining of the tissues, which causes some opacity in the parts. As a rule, however, the blood is pressed out of the vessels before the desiccating begins, and the stump is sufficiently translucent to enable the operator to see any vessel that has escaped. The indications or requirements for closing vessels are in this way thoroughly fulfilled by the complete fusing together of the walls of the vessels so that they do not, in fact can not, come apart. This I have demonstrated again and again. While I found in my first observations that the hæmostasis

was immediately complete, I was suspicious that when the tissue became softened by absorbing moisture the vessels might open up and subsequent bleeding might return, but many clinical experiences and experiments settled that question beyond all doubt.

## CHAPTER III

### RESULTS OF THIS HEMOSTATIC PROCESS

To my clinical observations I have the satisfaction and pleasure of adding an experiment made by Dr. R. L. Dickinson. He placed a mass of tissue, one part of which was treated by this method, into non-sterilized water and

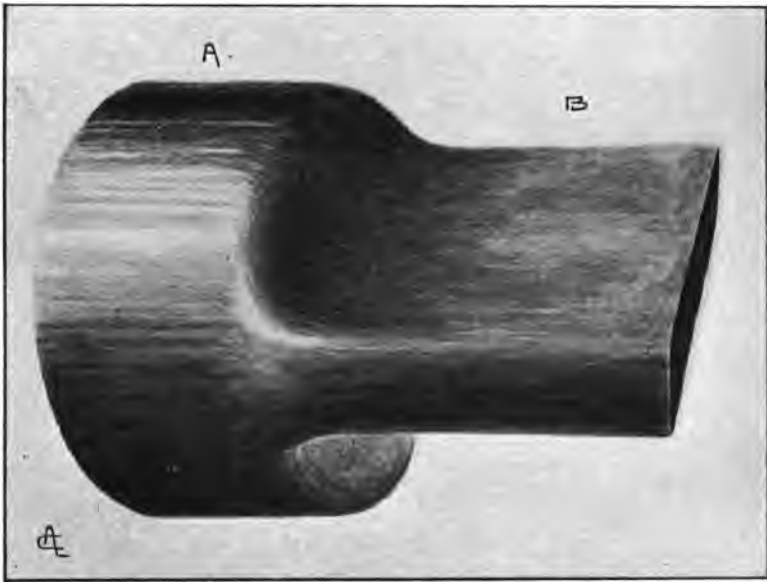

FIG. 11.—*A*, untreated end ; *B*, desiccated end.

let it remain immersed for about seventy-two hours. At the end of that time the tissue not treated was a soft pulpy mass that broke down under pressure of the fingers ; while the desiccated portion remained firm, though somewhat softened by the water, but with no separation of its component parts, neither could he find any part where cleavage

or dissection could be made. I have repeated this experiment many times with the same results.

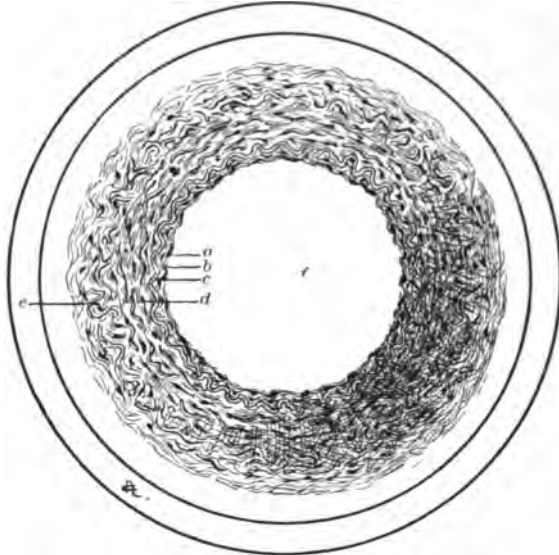

FIG. 12.—Section through *A*, Fig. 11: *a*, endothelial cells (intima); *b*, subendothelial layer (intima); *c*, internal elastic membrane (intima); *d*, media; *e*, adventitia; *f*, lumen of artery.

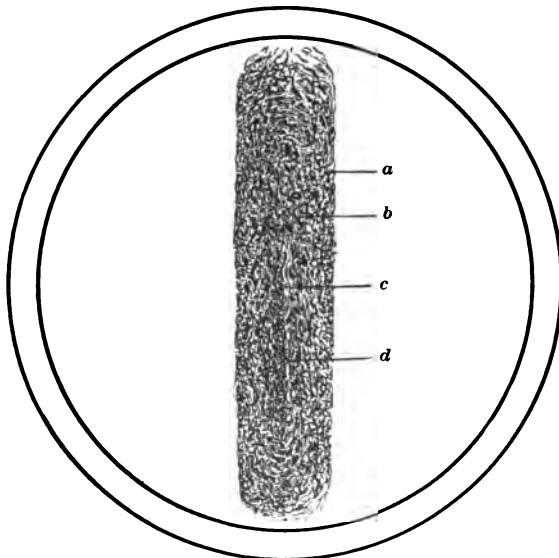

FIG. 13.—Section through *B*, Fig. 11: *a*, tunica adventitia; *b*, tunica media; *c*, tunica intima; *d*, line of closed lumen.

Finally, I may state that I have employed this method in over two hundred abdominal operations, and in many vaginal hysterectomies and other operations, and have never had secondary hæmorrhage in any of them.

These are the facts regarding the method as an hæmostatic. There still remains the question of the subsequent behaviors of the ends of the vessels and the tissue thus treated—in other words, the process of repair.

From all the facts that I could gather on this subject in actual practice, I concluded that the desiccated tissue became first hydrated and then reorganized, and remained as permanent structure, closing for all time the ends of the blood-vessels, lymphatics, and canals so treated. There was still an uncertainty on this point, until Dr. W. H. Seymour, the pathologist to my department in the college, conducted a series of independent experiments in the Hoagland Laboratory. The account of these observations and experiments by Dr. Seymour and the illustrations made under his supervision are as follows:

In the first place, the doctor observed that an artery a quarter of an inch in diameter was reduced to about a twelfth of an inch in thickness (see Figs. 11, 12, 13), and that the structure of the tissues was rendered amorphous by the heat and pressure. The lumen of the artery was obliterated completely, so that no trace of its original structure could be found. (See Figs. 14, 15.) A piece of tissue, containing arteries, nerves, fibrous, muscular, and areolar tissue, was treated in the same way and presented the same amorphous appearance and complete closure of the arteries. So completely fused together were the walls of the lumen of the arteries that no trace of the original structure could be found, neither could the lumen be reopened by teasing the microscopic specimen.

Observations were made of sections of the Fallopian tubes, appendix vermiformis, ureters, and other canals lined with mucous membrane, and the same amorphous conditions were found. The structure of the mucous mem-

brane was so completely changed that no part of its original structure could be found by microscopical examination.



FIG. 14 (under low power).—1, desiccated end; *a a'*, line of desiccation; *b*, lumen of artery; *c*, tunica intima; *d*, tunica media; *e*, tunica adventitia.

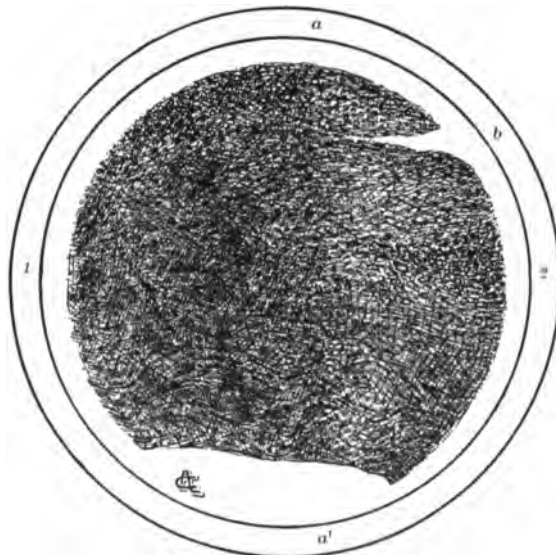

FIG. 15 (under high power).—1, desiccated end; 2, untreated; *a a'*, line of desiccation; *b*, remains of lumen.



The thoroughness of the closure of the arteries was demonstrated by attaching a fountain syringe to the opening of the artery and using double the ordinary blood pressure without opening the closed end of the vessel.

The advantages that may be fairly claimed for this way of controlling bleeding in surgery are, that it is certain and reliable in closing isolated vessels or those imbedded in masses of tissue, like an ovarian-tumor pedicle for example. At the same time that bleeding is arrested, all lymphatics are sealed up, which prevents septic absorption. The tissues of the stump are reduced to the smallest possible size, and there are no raw surfaces left to form adhesions to the abdominal or pelvic viscera, nor any foreign substance left in the tissues to cause mischief, advantages that can hardly be overestimated.

Tissues which have become friable by disease and can not withstand sufficient pressure of a ligature to control bleeding are easily managed by this method. When the tissues that form the pedicle of a suppurating ovarian cystoma or a pyosalpinx contain septic germs, a condition in which the ligature is most objectionable, a better and much safer stump can be made in this way. A ligature used when the tissues are in this condition, especially a catgut one, is very objectionable, for the dead animal tissue of such a ligature forms a perfect medium for the development of disease germs. It is also the only way that canals lined with mucous membrane—the Fallopian tube and the appendix vermiformis, for example—can be permanently closed. This will be referred to when discussing special operations.

Nerves that accompany the vessels are immediately devitalized, and hence there is less pain and irritation in the stump. The heat employed sterilizes the parts involved, and therefore the operation is perfectly aseptic. To these many advantages may be added that it leaves the stump of a pedicle or the end of an artery in a condition requiring the least reparatory care, so that recovery is more prompt, uneventful, and complete.



*Macroscopic and Microscopic Appearances of the Fallopian Tube treated with the Electro-hæmostatic Forceps.*

These observations have been made on two stumps, taken from canine subjects, at the end of the third and tenth day of the healing process, following laparotomy.

In each instance, prior to the application of the forceps, careful antiseptic measures were followed out in the exposure of the tube and uterus. The hæmo-

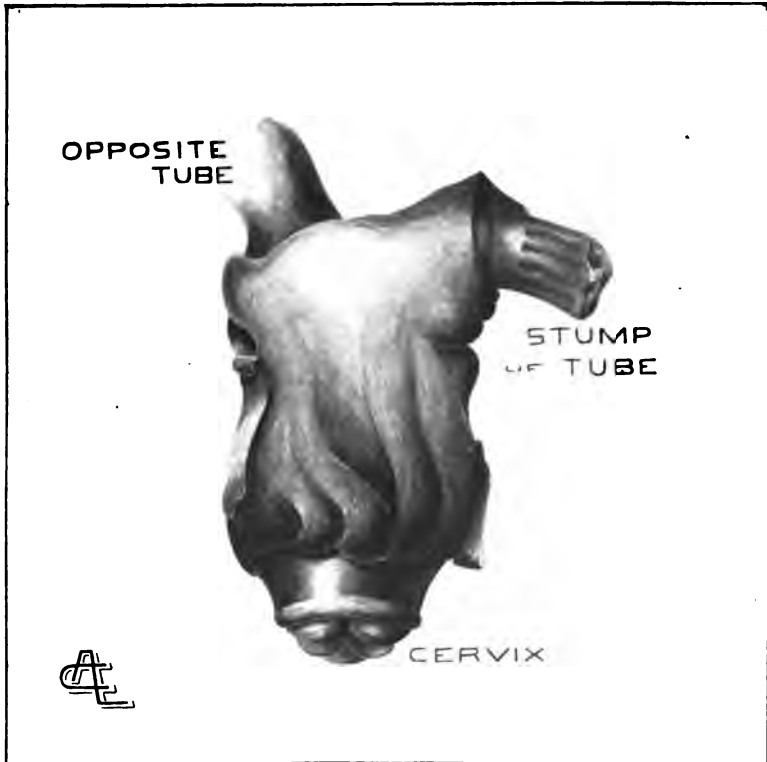

FIG. 16 represents the tube removed at the end of the third day of the healing process.

static forceps of the smallest size was placed on each stump for one minute, and an electric current used of sufficient strength to raise the temperature of the forceps to 180°.

**MACROSCOPIC APPEARANCE (Fig. 16).**—The forceps was placed about half an inch from the bifurcation of the uterus on the Fallopian tube, broad ligament, and blood-vessels. At the point of application is noted a constriction corresponding in width to the cautery clamp, on the surface of which are numerous corrugations which correspond to the same in the blades of the instrument. A decided compression is shown to exist at the point of application, and also a quantity of recent lymph

FIG. 1.

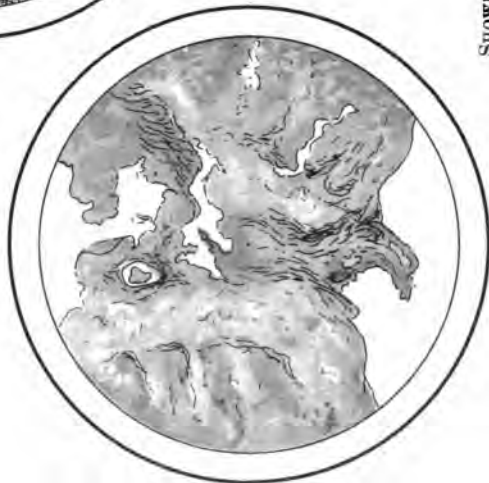
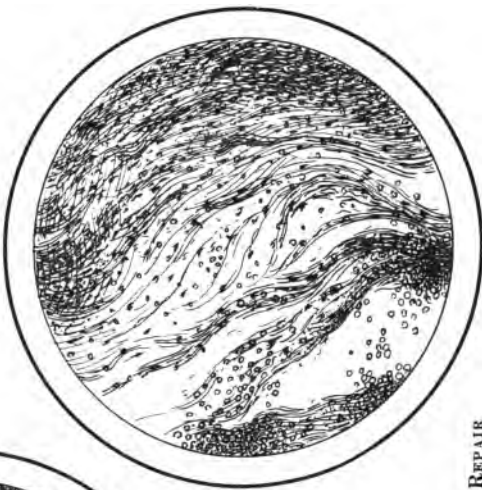

FIG. 2.



FIG. 3.



SHOWING SECTIONS OF STUMPS IN PROCESS OF REPAIR  
THREE DAYS AFTER SALPINGO-OOPHORECTOMY.

FIG. 1.—Showing lumen of tube obliterated by exudate. L. P.,  $\times 10$ .

FIG. 2.—Area of coagulation necrosis. L. P.,  $\times 50$ .

FIG. 3.—Same as 1, showing small round-cell infiltration. H. P.,  $\times 400$ .



and solid exudate found over the free end of the stump. Considerable ecchymotic hæmorrhage is noticed at the uterine end of the area treated with the hæmostatic forceps. The free end of the tube is seen to be softened, and corresponds in appearance with what might be expected in the earlier stages of coagulation necrosis.

On an examination of the luminal portion, macroscopically, the canal is seen to be obliterated.

**MICROSCOPIC APPEARANCE** (Plate I, Fig. 1, longitudinal section).—Under the low power (Plate I, Fig. 2) the mucosa and submucosa are everywhere infiltrated with countless small round cells; the blood-vessels are obliterated, their lumina being compressed. The free edges of the mucous membrane are seen to be in apposition, no distinct line of demarcation (luminal) being apparent. Considerable softening exists in the outer portions of the wall of the oviduct. The small round cells can, with little difficulty, be traced far back into the muscular layers of the organ.

Under the high power (Plate I, Fig. 3) are seen countless small round cells of the reparative process, intermingling with which are also fine fibrous elements surrounding small and large areas of coagulation necrosis. On studying the luminal portion of the mucous membrane the small round cells of one surface seem to merge or blend with those of the opposite, thus preventing the recognition of the luminal margin of the mucous membrane.

**MACROSCOPIC APPEARANCE** (Fig. 17).—The tube resembled, in its treated portion, that of the third-day specimen, the treated area, however, being much duller in

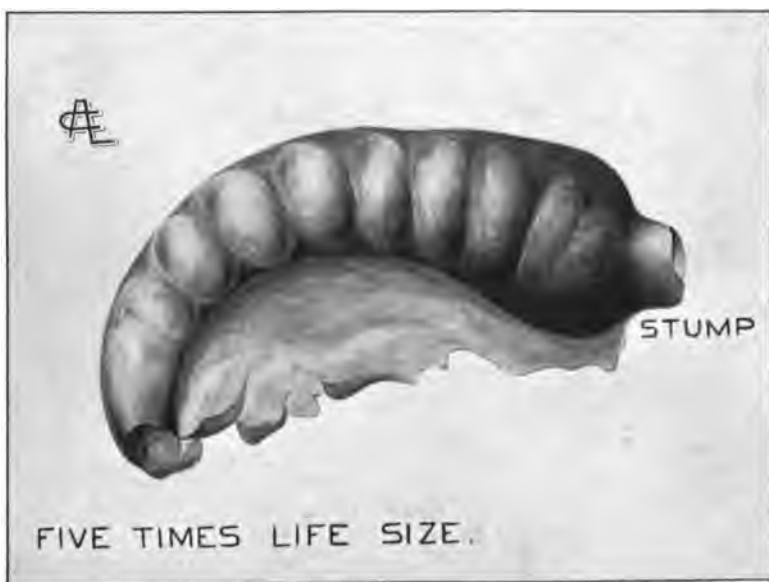

FIG. 17 represents the tube removed at the end of the tenth day of the healing process.

outline, firmer over its end, and containing much less softened material and lymph than in the former specimen. The lumen can not be macroscopically identified.

**MICROSCOPIC APPEARANCE.**—A section was made of a portion of the oviduct through the lumen and mucosa, longitudinally, at the point of application of the

## PLATE II.



FIG. 1.

FIG. 2.

REORGANIZATION OF THE STUMP AFTER ELECTRO-HÆMOSTASIS, TENTH DAY.  
 Fig. 1, area of coagulation necrosis, low power. Fig. 2, area of coagulation necrosis, high power.

hæmostatic forceps. The duller portion represents marked areas of coagulation necrosis, together with some hæmorrhage by diapedesis, shown in adjacent neighborhoods.

The mucosæ of the two walls of the tube are seen to be in contact, thus producing *actual obliteration* of the lumen of the tube *due to active proliferation* of the cells of the mucosa and infiltration of small round cells.

Plate II, Fig. 1, represents one of the areas of coagulation necrosis in the more superficial portion of the mucous membrane. Plate II, Fig. 2, represents a smaller area more highly magnified, showing countless small round cells from infiltration processes.

## CHAPTER IV

### ELECTRO-HÆMOSTASIS IN OVARIOTOMY

THE part of this work relating to the management of hæmorrhage in abdominal and pelvic surgery is of necessity fragmentary, as it treats of hæmostasis in this class of operations only. In describing this method of arresting the hæmorrhage which occurs when making the abdominal section, separating adhesions, and treating the pedicle in ovariectomy, I shall follow the steps of the operation in the order in which they have just been named.

The *hæmorrhage in abdominal section* comes mostly from the vessels of the skin, and should be arrested if at all free before dividing the deeper structures. The vessels should be seized with the artery hæmostatic forceps and heated under pressure until they are closed. The method of treating small vessels in incised wounds is fully described under the head of extirpation of the mammary gland, which will be described in a later chapter. If the incision in the deeper structures of the abdominal wall is made in the median line, as it should be, and the large veins that are sometimes found in the peritoneum are avoided, no important hæmorrhage occurs. The advantages of treating bleeding vessels in this part of the operation are that no ligatures are left in the wound, and the injury of tissue caused by twisting the arteries or bruising them with compression forceps is avoided, and therefore the tissues are left in a better condition to heal promptly. It is my opinion that this is a very important factor guarding against subsequent ventral hernia.

*Adhesions of the omentum* to the cyst wall or tumor are treated by making traction upon the cyst wall to bring it and the adherent portion of the omentum out of the abdominal wound. A narrow-bladed forceps is applied to the omentum, close to the cyst wall, and the portion in the grasp of the forceps heated under pressure until fully desiccated. The portion thus treated is divided near to the cyst wall but in the line of desiccation. See Fig. 18, which shows a part that has been treated and divided, and another portion in the grasp of the forceps. In cases having a large portion of the omentum surface attached the adherent part can not be brought out of a small-sized

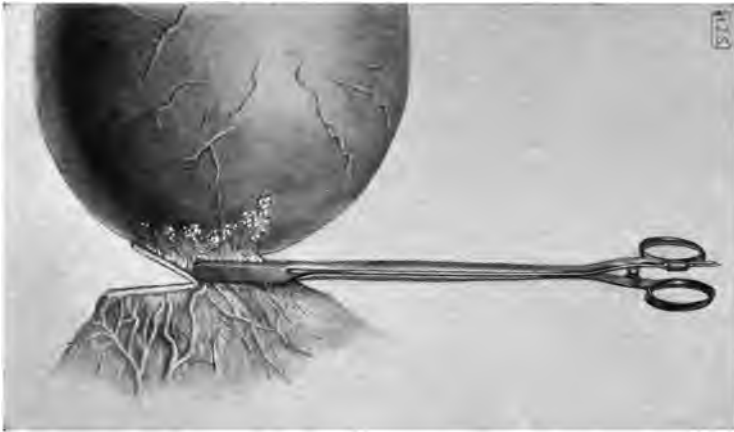

FIG. 18.—The treatment of omental adhesions.

wound far enough to reach the free portion to be separated. In such conditions the incision should be enlarged sufficiently to facilitate the operator's manipulations partially within the abdominal cavity. Great care is necessary in such cases to protect the intestines from the heat while the forceps is being used. Fortunately such adhesions are very rare. The omentum being thin and the vessels small, only about twenty to thirty seconds are required to close them. In rare cases, when the omentum is thickened by inflammation, and the vessels very much enlarged, a minute of the heat may be required.



*Adhesions of the Appendix Vermiformis.*—The appendix is found adherent in pyosalpinx quite frequently, and is discussed in connection with that subject. Suffice it to say here that when the appendix is adherent to an ovarian tumor it should be removed with the



FIG. 19.—Artery forceps.

tumor. The method of removing the appen-

dix is given in the chapter on appendectomy.

The raw, bleeding surfaces left after separation of adhesions to the wall of the abdomen, deep down in the sac of Douglas or elsewhere, are treated first by seizing the largest bleeding vessels with the artery forceps (see Fig. 21) and closing them. Then the oozing from the very small vessels is stopped by using the dome-shaped instrument. (See Fig. 35.) This is slowly passed over the surfaces until all oozing ceases.

The operator must guard against letting the intestines, uterus, or bladder come into contact with the dome instrument when it is in use. With ordinary care the needed protection can be assured by having the patient in the Trendelenburg position and keeping the abdominal and pelvic viscera out of harm's way with sponges and retractors, as illustrated in Fig. 21.

The technique is exceedingly simple, and the results most satisfactory compared with the old way of ligating the larger vessels (always a most difficult thing to do) and using persulphate of iron or hot water to stop the oozing.

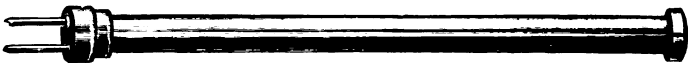

FIG. 20.—The dome.

In fact I never was able to arrest bleeding and oozing completely and quickly, and make the parts clean and dry in pelvic surgery of this kind until I devised this method of operating.

*Intestinal adhesions* are managed by making gentle traction and stretching the adhesion so that the forceps can be placed between the cyst wall and the intestines. While the pressure and heat are being applied, the shield forceps should be placed on the side toward the intestines to protect them. When this is impossible, owing to close and extensive adhesions, the intestine is dissected away

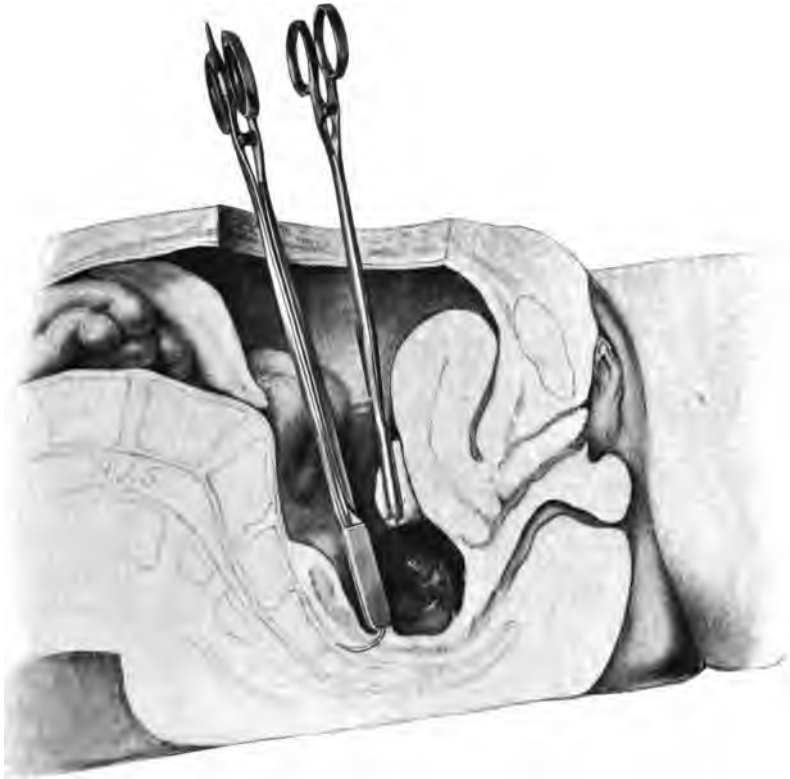

FIG. 21.—Protecting the uterus from the forceps.

from the cyst in such a manner as to leave a portion of the external coat of the cyst wall on the side of the intestine. These flaps are brought together over the raw surface of the intestine and seized with the forceps, compressed and desiccated. (See Fig. 22.)

In doing this the shield forceps should be used to keep the heat from reaching the intestine. This instrument

resembles an ordinary compression forceps, but has thin, flat shields instead of jaws, as shown by Fig. 23. The shields are constructed of thin blades of steel coated with a substance which is a poor conductor of heat, such as hard rubber, and are longer and broader than the jaws of the electrical forceps. One side of each shield is flat and the other is beveled, as shown, so that the inside edges are chisel shaped. The flat sides are placed uppermost, close against the electrical instrument. When properly placed, the shield forceps is locked with sufficient pressure to re-

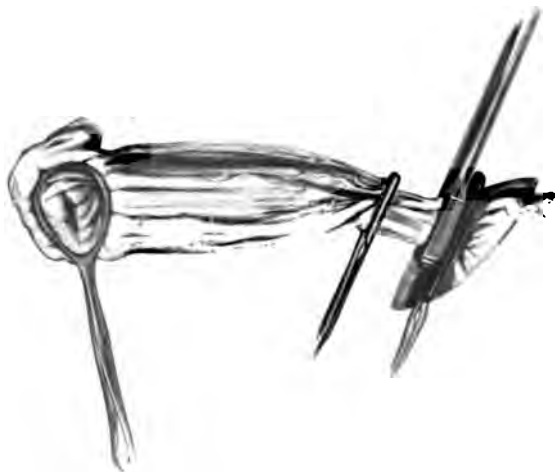

FIG. 22.—The treatment of intestinal adhesions.

tain the desiccated stump for inspection after the other instrument is removed.

*Adhesions to the rectum* (the most difficult of all to manage) are treated in the same way as intestinal adhesions, with this difference, that when the adhesions are very strong, and the cyst wall changed in structure by inflammation, a part of the cyst wall should be left attached and its lining membrane destroyed with the dome cautery.

*Adhesions of the bladder* to the tumor are treated by dissecting off the bladder and then closing the peritoneum

over the bladder with fine catgut sutures. Adhesions that are recent, not very extensive, and easily separated, are treated by touching the raw surface with the dome cautery

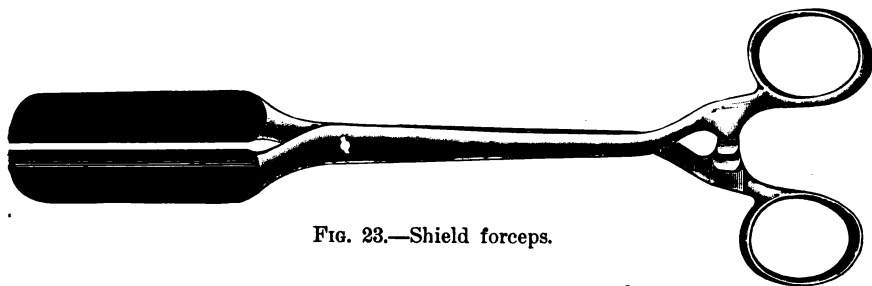

FIG. 23.—Shield forceps.

at a temperature of  $180^{\circ}$ , to arrest any oozing that may take place.

*The Pedicle.*—The cyst sac or tumor being withdrawn from the abdominal cavity the pedicle is examined with regard to its length and thickness, to determine the point at which it should be divided, and the size of forceps or clamp required for its treatment. Small and medium-sized pedicles call for the smallest pedicle forceps, illustrated by Fig. 24, and constructed as follows: The instrument is jointed at the distal end by a detachable lock, and has a projection on either blade at the proximal end of the jaws, which prevents the tissues from spreading when the forceps

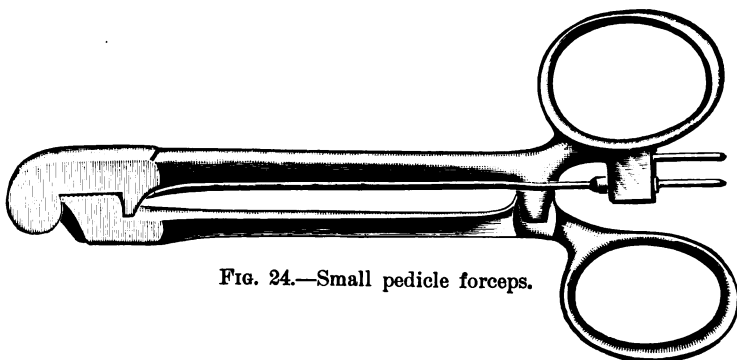

FIG. 24.—Small pedicle forceps.

is closed. The handles lock with the usual catch near the proximal end. Larger pedicles require the clamp forceps, illustrated by Fig. 25, and constructed in the same man-

ner as the small pedicle forceps, but having a movable section which can be closed by a screw attachment. By this means the pressure is made parallel to the heated jaw, and a greater and more equal compression is thereby ob-

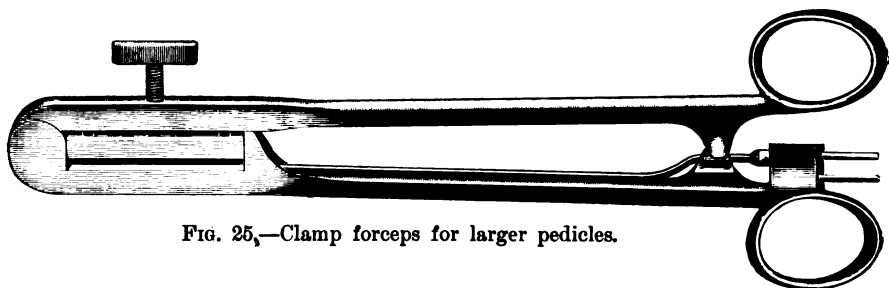

FIG. 25.—Clamp forceps for larger pedicles.

tained. The forceps selected is applied at the point where the pedicle is to be divided. One or two fixation forceps are applied to the base of the tumor, and the pedicle divided between them and the hæmostatic clamp, leaving a portion of the pedicle projecting above the blades of the clamp to prevent slipping. This portion should be cut off close to the forceps just before removing it. The shield forceps is applied beneath the hæmostatic forceps to protect the abdominal wall from the heat, and to keep the stump from falling back into the pelvic cavity when the hæmostatic forceps is removed. (See Fig. 26.) This enables the operator to inspect the stump and see if it has been properly treated before it is dropped. If any portion of the stump, or the whole of it, indeed, is not fully desiccated, the forceps can be reapplied and the treatment completed.

Sterilized vaseline should be applied to the inner surface of the blades of the forceps, to prevent the stump from adhering and to permit the forceps to come off easily. The forceps should be closed only to the first notch in the catch, and when the current has been turned on and used for about half a minute the compression should be completed by closing the forceps to the last notch. During the time that the electric current is being used the operator should examine

the other ovary and the other pelvic organs to see if anything more in the way of operating is required.

An unusually short, thick, broad pedicle, that can not be accommodated in the largest clamp forceps, should be treated in three sections. The outer border, which contains the ovarian vessels, should be grasped with the forceps used for vaginal hysterectomy, treated in the usual way, and divided; the inner border should be treated in the same way; the middle portion, or third section of the pedicle, if not vascular may be cut off without treatment,



FIG. 26.—Treatment of pedicle of ovarian cyst. (Diagrammatic.)

and the edges of the peritoneum of the stump closed with fine sutures. If the middle part is vascular it should be caught in the pedicle clamp and treated like the other sections.

For one who is not familiar with this treatment of the pedicle it is difficult to tell when the treatment is sufficient to be reliable. This was to me a most difficult question in my first operations, but I soon learned that if there was no disposition to bleeding when the clamp was removed, it could surely be trusted.

## CHAPTER V

### ELECTRO-HÆMOSTASIS IN MYOMECTOMY AND ABDOMINAL HYSTERECTOMY

I DID a number of successful myomectomies in pedunculated fibroids, and in all I found difficulty in controlling the bleeding with the ligature. Such was my experience that I never dared to remove a sessile subperitoneal fibroid until I obtained the hæmostatic forceps. Since then I have succeeded equally well with all forms

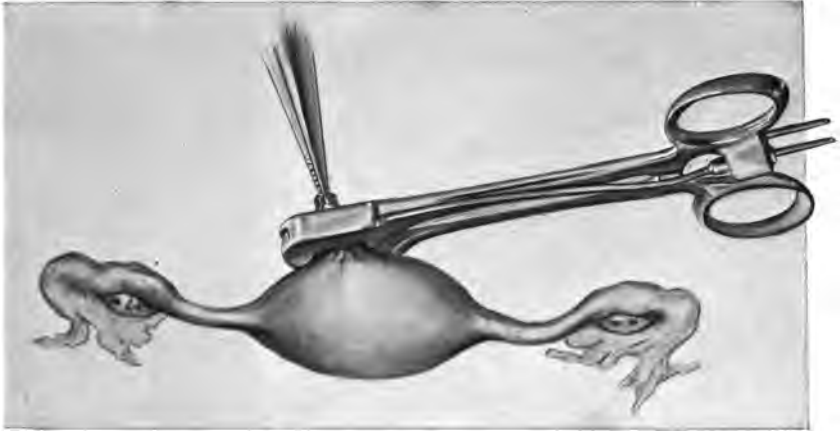

FIG. 27.—Treatment of pedicle of a fibroid. The cuff of peritoneum and the capsule gathered together, drawn outward, and seized by electro-hæmostatic forceps.

of subperitoneal fibroids. The method of operating when the pedicle is long enough is to apply the forceps in the same way as it is used upon the pedicle of an ovarian tumor, compress and desiccate it, and then cut away the tumor.



When the pedicle is short and the fibroid is in contact with and yet movable upon the middle coat of the uterine wall, the capsule is divided all around on the tumor one to two inches from the uterus. It is then dissected off with



FIG. 28.—Line of incision preparatory to enucleation of sessile fibroid.

the dry dissector until the tumor is enucleated; the empty portion of the capsule is finally gathered together and grasped in the forceps and desiccated by the electric heat. (See Fig. 27.)

The shield forceps is used to protect the uterus from the heat. The redundant part of the stump which projects beyond the blades of the forceps should be cut cleanly off after the treatment is completed, and before the forceps is removed.

Sessile fibromata are treated in the same way, excepting



FIG. 29.—Sessile fibroid enucleated. Showing cuff of peritoneum.

that when the attachment of the tumor to the uterus is quite broad the incision of the capsule should be made higher up on the tumor—that is to say, it should be nearly as high as the diameter of the base of the tumor (Fig. 28).

When the incision is made, and enough of the capsule has been freed from the tumor to get hold of, ordinary compression forceps should be used to control bleeding until the enucleation is completed (Fig. 29). The two sides of the capsule should be held apart while the surface of the uterus from which the tumor was detached is carefully in-

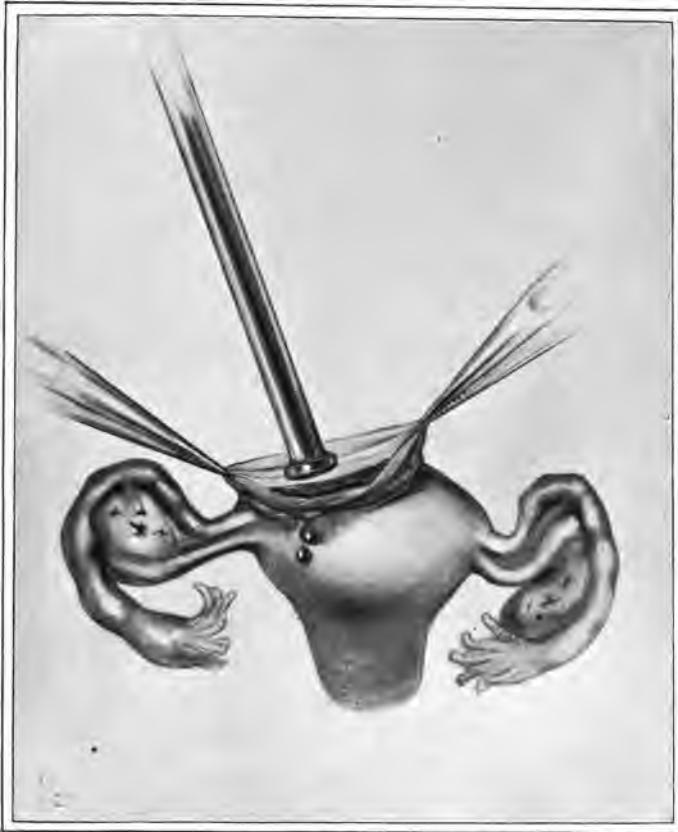

FIG. 30.—The use of the dome in treating bleeding raw surface after enucleation of sessile fibroid.

spected, and all oozing stopped by the application of the dome cautery mentioned in the description of ovariotomy (Fig. 30). The flaps of the capsule should be brought together, grasped by the forceps, compressed and desiccated (Fig. 31). This completely arrests all hæmorrhage, and

leaves the smallest possible stump. Occasionally several small subperitoneal fibroids accompany one or more large ones. These little ones are quickly disposed of by making an incision through the capsule at the summit of the tumor

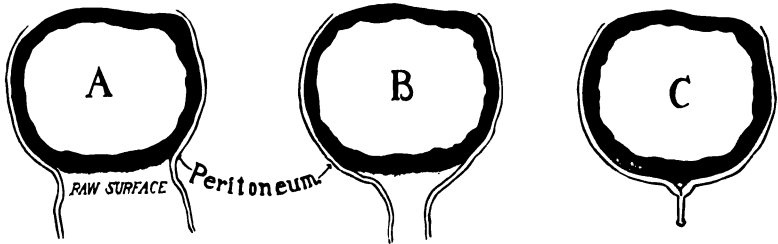

FIG. 31.—Steps in treating stump after enucleation of sessile fibroid.

with the cauterizing knife, and enucleating and treating the sac or capsule as already described.

#### ABDOMINAL HYSTERECTOMY FOR FIBROMATA

The abdominal incision is made long enough to permit lifting both the uterus and the tumor out of the abdominal cavity. The body of the uterus is drawn toward the left side, and the right side of the abdominal wall is retracted, so that the right broad ligament is fully exposed. A compression forceps is applied to the upper part of the broad ligament, including the ovarian artery, near the brim of the pelvis. Another forceps is applied opposite the first one, near the uterus. The round ligament is caught in a forceps in the same way and the ligament divided down to near the uterine artery. The lower part of the ligament is opened up and the uterine artery found and caught in a compression forceps. If the artery can not be separated from the tissues of the ligament without much trouble, the ligament and artery may be seized *en masse*. The uterus is separated from the bladder, and the cervix uteri divided or amputated in the usual way. The uterus is tilted still farther to the left side to bring up the lower portion of the broad ligament and left uterine artery. This also is seized by compression forceps and the

ligament divided from below upward. Forceps are applied to the round ligament and the ovarian artery when they are approached in the process of dividing the ligament. Fig. 32 shows the line of incision, and Fig. 33 shows the excision of the uterus and the temporary control of the arteries with compression forceps.

The tumor having been thus removed, the treatment of the vessels is accomplished as follows: The divided end of the artery is caught up with a fine dissecting forceps and drawn out of the tissues of the ligament and seized with the hæmostatic forceps, compressed and desiccated. When it happens that the broad ligament has been divided close up to the compression forceps, the artery can not be iso-

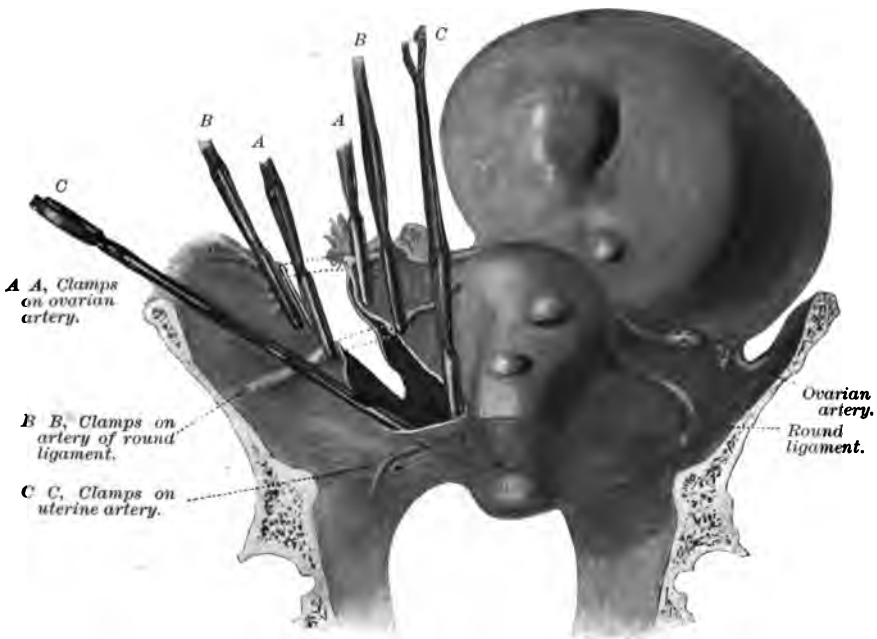

FIG. 32.—Treatment of right broad ligament and temporary control of vessels.

lated sufficiently without taking off the forceps; but if the end of the artery is grasped with the dissecting forceps the tissues can be stripped back from the artery far enough to admit the grasp of the hæmostatic forceps. Fig. 34 shows

the ovarian artery after it has been closed, and also the uterine artery in process of being closed or treated.

I was fearful that the pressure of the forceps upon the broad ligament if continued for any great length of time

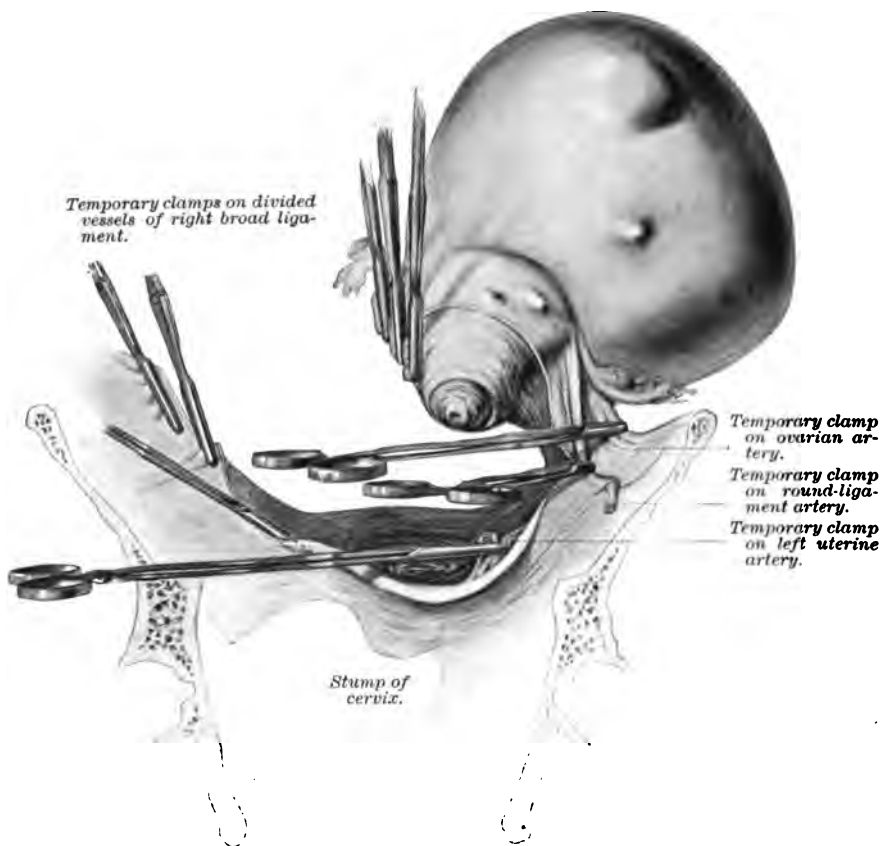

FIG. 33.—Treatment of left broad ligament and temporary control of vessels.

might so bruise the tissues that sloughing would take place, and the process of repair be thereby retarded. So I treated each artery as it was divided—that is, the compression forceps was applied lightly, and the artery and ligament divided and immediately closed with the hæmostatic forceps. Then the other arteries were treated in the same way. Experience, however, indicates that unless the compression of the tissues is greater than necessary, the damage done is

not sufficient to retard repair; the circulation is re-established, and healing goes on rapidly.

The peritoneum is closed over the broad ligaments and stump of the cervix uteri with running catgut sutures. Beginning above on the left, one suture is introduced along to the center of the cervix, the other suture is applied from above downward on the right side until it meets the suture of the left side, and the two are secured by tying their ends together.

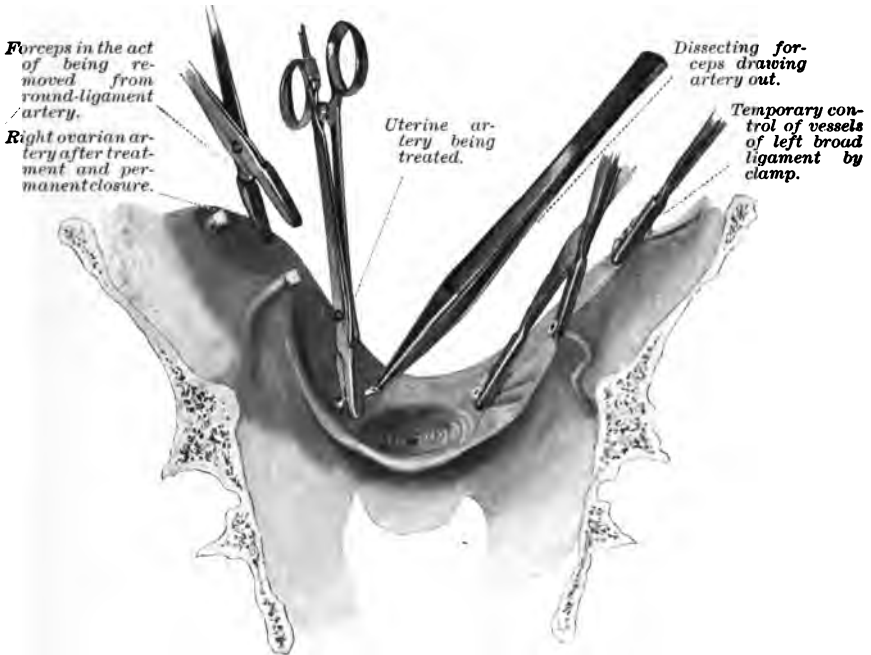

FIG. 34.—Final treatment of vessels.

When it is necessary to remove the entire uterus, the exsection of the cervix is added to the operation above described. There are two ways of doing this: circumcising the vagina from below, or opening and detaching it from above. Certain advantages belong to both ways of operating in certain conditions; therefore the surgeon should select the method adapted to the conditions in cases as they come.

When the cervix is within reach from the vagina, it is easier to circumcise the cervix uteri through the vagina, and the lower portion of the bladder can be more easily and safely separated from the uterus in this way than through the pelvic cavity from above. The disadvantages of this method are, that it increases the time of operating, especially when the vaginal wall is vascular, since time is required to stop the bleeding before opening the abdomen. But when the cervix uteri is drawn up out of, or crowded to one side of, the pelvis, it is better to separate the cervix and vaginal wall from above.

The method of operating which I have adopted saves time enough to make it preferable, in my judgment, in suitable cases.

Two incisions in the vaginal wall, one in front and one behind the cervix, are made, so that they meet on either side of the cervix; the bladder is separated from the uterus up to the peritoneum, the vagina is separated from the posterior wall of the cervix, but the peritoneum is not opened. By this procedure the lower portions of the broad ligaments are exposed. The hæmostatic forceps used in vaginal hysterectomy is applied to the lower portion of one ligament, which is compressed and desiccated, and cut off from the supravaginal portion of the cervix. The other side is treated in the same way. This frees the cervix from all of its attachments, except the peritoneum, and at the same time arrests all bleeding from the vessels which supply the vagina. This part of the operation is performed precisely as the first steps in vaginal hysterectomy. The abdominal part of the operation is performed as already described, except that in place of amputating at the cervix, the peritoneum in front and behind the cervix uteri is opened toward the incision made from the vagina.

It is sometimes found that when the uterine artery is ligated and the ligament divided down to the part separated from the vagina there is a branch of the uterine or vaginal artery that bleeds; this is easily controlled by using



the hæmostatic forceps. The dome is very useful in arresting capillary oozing in the deep locations hardly accessible by other means. (See Fig. 35.) The peritoneum is closed over the broad ligaments in the way already described, and the vagina is closed by interrupted suture, including the peritoneum and vaginal walls.

The reader will observe that I have adopted Kelly's method of doing this operation, only slightly modifying it

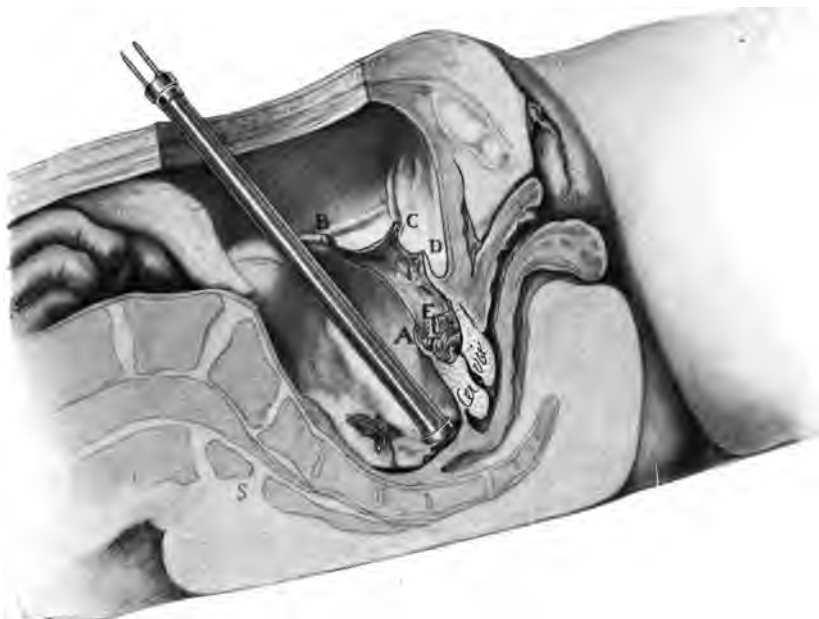

FIG. 35.—The use of the dome deep in the *cul-de-sac* to arrest persistent oozing. The patient is in the Trendelenburg posture. The uterus has been removed. The treated stumps of the vessels are shown: *B*, ovarian stump; *C*, stump of artery of round ligament; *E*, compressed and heated stump of uterine artery; *A*, posterior, and *D*, anterior peritoneal flap.

to suit the new method of controlling the bleeding vessels. Dr. Kelly, in describing his method of doing abdominal hysterectomy, adds some valuable remarks regarding its advantages in complications, which I quote here:

“I have insisted particularly upon the novel way in which serious complications are simplified by this plan of treatment, and I would refer chiefly to two kinds of complications:



“First, fibroid tumors located under the peritoneum of the pelvic floor; and,

“Second, inflammatory masses situated behind the broad ligaments, with dense adhesions to the pelvic peritoneum, to the rectum, and often to the small intestines.

“In the case of the subperitoneal pelvic fibroids, it is astonishing how difficult they are to get at from above, and how easily, on the other hand, they roll out when handled from beneath by this procedure.

“I would say the same of the inflammatory cases. Matted masses, adherent in all directions, which resist enucleation from above, are often removed with ease when rolled up from the pelvic floor from below. The adherent structures seem to be unrolled in a natural and easy way, in surprising contrast to the difficulties experienced and the injuries inflicted in gaining the slightest fingerhold in proceeding from above.

“To recapitulate: Abdominal hysterectomy by the continuous incision down through one broad ligament, across the cervix and up through the other broad ligament, is contrasted with hysterectomy by an incision down to the cervix through one broad ligament, and then down through the other, followed by amputation of the cervix.

“The special advantages offered by this method of operating are:

“1. The saving of from sixty to eighty per cent of time in the enucleating stage of operation.

“2. The ease with which intraligamentary myomata and myomata beneath the pelvic peritoneum may be enucleated.

“3. The ease with which inflammatory masses posterior to the broad ligament may be enucleated by attacking them from below after dividing the cervix.

“4. The control of a displaced ureter on the side last opened up, keeping it out of the way of injury by the simple mechanism of the operation.”

## CHAPTER VI

### ELECTRO-HÆMOSTASIS IN OVARIO-SALPINGECTOMY

ALTHOUGH the mortality in operations for pyosalpinx and kindred diseases of the tubes and ovaries has been reduced to a minimum, there has been such a large percentage of incomplete recoveries that some of the best-known surgeons have expressed dissatisfaction with the ultimate results. During my investigation of this class of uncured cases, I found that ligation of the pedicle had been practiced in all of them, and that all kinds of ligatures had been used, while in those treated with the cautery clamp, according to Keith's method, no such results followed. Those who recovered after that treatment were permanently relieved. I naturally inferred from this that the ligation was the cause of the unfortunate effects, and in one sense that is the case. In explanation I must say that while the ligature itself is the cause of some trouble, the worst afflictions come from patency of the Fallopian tubes, which remains after treatment by ligation.

Professor Emil Ries, of Chicago, has given (see *American Gynæcological and Obstetric Journal*, January, 1898) the unfavorable results following the removal of the tubes and ovaries, and the causes thereof, in a most interesting and valuable essay, from which I have taken the following. After noticing that Schauta and Chrobak report but little more than fifty per cent of their laparotomy patients as really cured, Dr. Ries suggested that one of the most important causes of these unsatisfactory results was to be found in the formation of stump exudates, and offers a new

explanation of this cause in the following observation of several cases in which microscopical examinations were made of the uteri removed some time after salpingectomy.

“Stump exudates were found by Schauta in twenty-eight cases out of his one hundred and seventy-two salpingo-öophorectomies. They have been found even more frequently by other observers, and in my own experience I have repeatedly found them to be at the bottom of troublesome symptoms months after the operation. They produce pain, sometimes so severe that the patient is unable to attend to her work; in some cases the pain is even worse than it was before the operation. The exudates are found around the stumps of the removed tubes, and vary in size from a barely palpable thickening of the uterine horn to the size of a hen's egg or larger.

“As an explanation of the formation of these tumors, Schauta offered the following two possibilities:

“1. The inflammatory process creeps on through the uterine wall into the surrounding parametric and perimetric tissue; and,

“2. Germs were present in the broad ligament at the time of the operation (though no actual observations could be offered as evidence of this), the connective tissue of the broad ligament was laid bare by the operation, and in this way the germs could invade the peritoneum.

“Though these observations did not meet with any opposition, it can not be overlooked that we have no observations bearing out the correctness of these hypotheses. Besides, I can not help feeling that they are very artificial.

“The cases are as follows:

“CASE I.—Mrs. J., twenty-four years old. Seven months previously a left pus tube and ovary had been removed. A sinus remained which would not close. Besides, the patient has an ovarian abscess the size of a fist, and hydrosalpinx on the right side. Uterus adherent all over, forming part of the wall of the sinus. I operated September 28, 1896. Laparotomy. Removal of ovarian

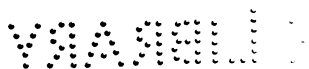

abscess, hydrosalpinx, uterus ; excision of sinus, which leads toward the right crista ili and terminates in an abscess which contains five silk ligatures. Recovery.

“The stump of the tube which had been removed seven months previously is excised, and examined in a series of sections, embracing the entire stump up to the interstitial portion of the tube. *The cavity is open throughout.* The epithelium is the usual low columnar epithelium of this portion of the tube, and stops at the surface of the stump without investing the cut surface of the stump. No threads to be found in the stump.

“CASE II.—Miss W., twenty-five years old. Several years ago removal of both tubes and right ovary. Now chronic pelviperitonitis and adherent retroflexion. Operation by Dr. W. H. Rumpf, on December 8, 1896. Vaginal hysterectomy.

“Both tubal stumps are examined in series. *They are perfectly permeable,* though the cavity is very narrow. Epithelium well preserved up to the abdominal opening of the stump. Besides, the left tube contains some epithelial ducts outside the circular muscular layer of the tube, one of which enters the circular muscular layer itself, but does not show any communication with the tubal cavity (remnant of the Wolffian body). No threads to be found in the stump.”

At a meeting of the American Gynæcological Society, held in Boston, June 26, 1898, Dr. J. Wesley Bovee, of Washington, D. C., read a paper on Patency of the Stump after Salpingectomy, in which he said that he had taken a special interest in this subject since 1892, and had found in five specimens from cases of salpingectomy that the stumps were still pervious. So far as he knew, only three well-authenticated cases had previously been reported. As I remember the reading of the doctor's paper, he accounted for the patency by saying that the ligatures might become infected and slip in course of time, or “mass” ligatures might slip off after closure of the abdomen. He

suggested that these stumps might be successfully occluded by cutting out the Fallopian tube by a wedge-shaped incision into the uterine wall at the tubo-uterine junction and closing the wound with sutures. Care must be taken he said, in the ligation of the uterine artery in this situation, and also not to pass the sutures through the *mu cosa*.

It appears that Dr. Bovee was not acquainted with the work of others when his paper was prepared, but he deserves credit for suggesting a way of overcoming the patency of the tube which so often follows the use of the ligature, and for adding five more to the list of unsuccessful cases following the usual method of operating. This method suggested by Dr. Bovee may be an improvement upon the old way of operating. Still, it requires longer time to introduce sutures than to use a ligature, and if the end of the tube is septic the wound in the uterus is sure to become contaminated and so complicate the process of repair that trouble may follow. At any rate I am quite confident that better results are obtained more easily by the method which I have adopted.

The operation for the removal of the tubes and ovaries should be adapted to the pathological conditions presented in given cases, simple and complicated.

The incision into the abdominal wall should be short, just sufficient to admit two fingers. Extra care is necessary to avoid wounding the omentum or bowels. If there are adhesions of the intestines to the abdominal wall, the incision should be enlarged in order to find a part where the peritoneum can be safely opened, and from which the adhesions can be treated. This is easier than to separate the intestines from the peritoneum in the incision. This complication is, fortunately, seldom met. I have occasionally found the omentum adherent to the tube and ovary, and sometimes to the abdominal wall near the median line; but it is generally free on one or both sides, so that the tubes and ovaries can be reached by passing the fingers outward be-

yond the adhesions on the side, and then drawing and pushing the omentum out of the way. When no free part can be found, the omentum should be picked up and divided in or near the median line, and the bleeding vessels closed with the hæmostatic forceps. Two fingers should be passed into the wound and the fundus uteri found. This is a guide to the tubes. Adhesions, when they are not too old and strong, should be separated with the fingers, but care must be exercised not to rupture the tube. When both tube and ovary are freed from adhesions, they should be hooked up with the fingers and brought out through the wound, or up into it. By traction in this way a pedicle is formed, included, and held between the fingers until the hæmostatic forceps is applied, the shield forceps adjusted, and the pedicle treated in the way described under the head of Ovariectomy for Ovarian Cystomata. (See page 37.)

One sometimes finds the pedicle too short to permit the tube and ovary to be drawn out of the wound far enough to apply the forceps outside of the abdominal wall. In that state of affairs the hæmostatic forceps is applied under the fingers in the abdominal incision, the distal end dipping down into the cavity. The shield forceps is applied from the same side as the hæmostatic forceps, and a retractor is used to keep the side of the abdominal wall and intestines away from the point of the forceps while the heat is being applied.

Cutting away the tumor or tube and ovary is always a serious matter, owing to the tendency of the septic contents to escape and contaminate the stump and wound; to some extent this is always the case when the ligature is used. The desired object is accomplished by not making traction upon the parts to be removed while the heat is being applied. When the pedicle is thoroughly desiccated the part to be excised joining the forceps becomes closed by the heat sufficiently to prevent leaking after being divided. With a sharp knife the parts are cut close to the

forceps, while care is taken not to make pressure on the tube and force out its contents.

In pyosalpinx complicated by firm and extensive adhesions the operation is altogether different. The outer ends of the tube and ovary are freed from adhesions until the ovarian artery is reached and that portion of the broad ligament caught in the forceps, closed with pressure and heat and divided. This liberates the tube and ovary so that they can be brought out through the wound (in case the adhesions of the tube are not very firm), and the uterine end of the tube and the remaining portion of the

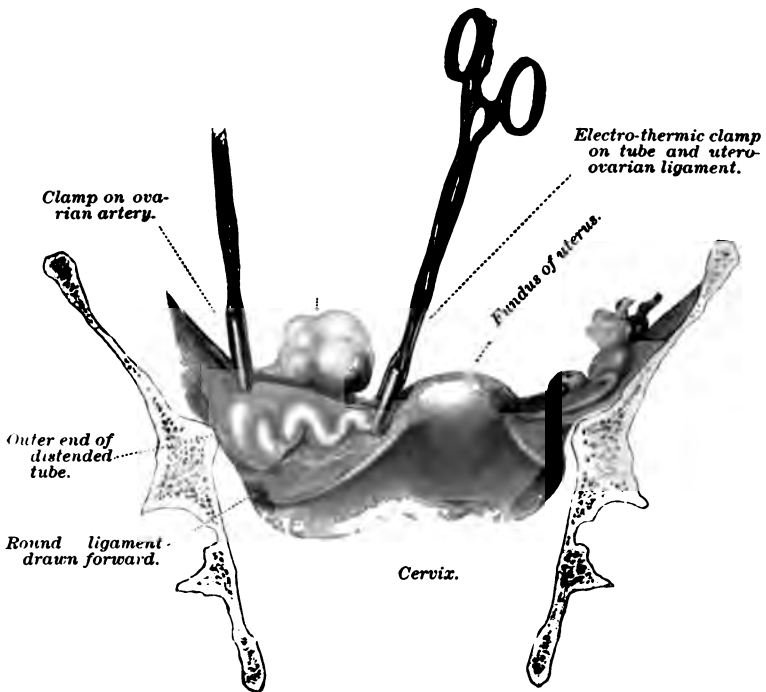

FIG. 36.—Removal of diseased tube and ovary by the forceps. Partly diagrammatic.

mesosalpinx can be grasped with the hysterectomy forceps or hæmostatic clamp, sealed up, and the tube and ovary cut away. (See Figs. 36 and 37.)

If the tube is distended close up to the uterus and the



adhesions are extensive, the operation has to be modified still more. After closing the ovarian artery and dividing that portion of the pedicle, the ends of the tube and ovary are dropped back, and the forceps having been applied to

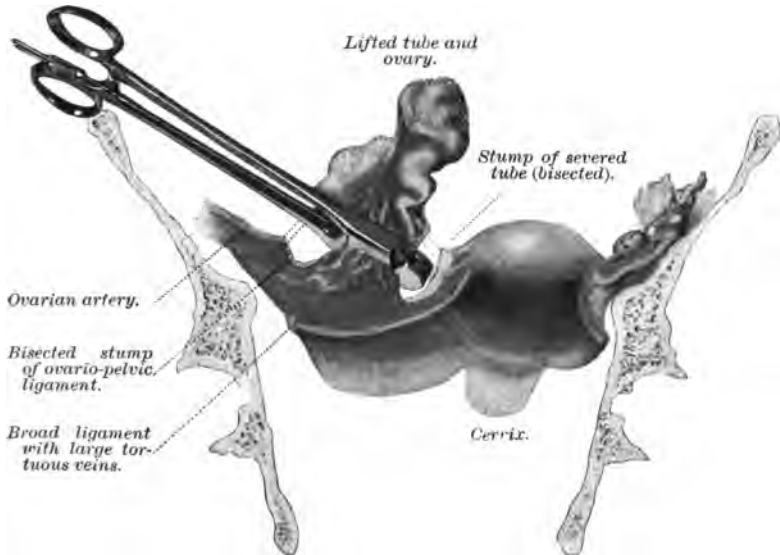

FIG. 37.—Second step of salpingo-oöphorectomy whenever the broad-ligament veins are enlarged.

the tube close up to the uterus, they are thoroughly compressed and desiccated, and then divided in the line of the closed portion of the tube. A traction forceps is applied to the end of the tube to keep it from falling back into the pelvic cavity. The separation of the adhesions is completed and the tube and ovary brought out of the wound, and the remaining pedicle—that is, the mesosalpinx—treated in the usual way with a small hæmostatic forceps. If the adhesions are old and vascular there is generally some oozing from the raw surface of the broad ligament, and this should be stopped by passing the dome cautery heated to 185° or 190° over the oozing surfaces until they are dry.

If the tubes are largely distended and their walls are thin, the adhesions should be separated only where that



can be easily done; the tubes are emptied, or partially so, with the aspirator, and then seized with the forceps and brought out. The adhesions should be separated by dividing them with scissors, or, if very vascular, the hæmostatic forceps should be used. The pedicle is then treated in one mass or in three sections as last described.

When both tubes and ovaries are diseased, especially in double pyosalpinx, the uterus should also be removed. The operation is then performed in exactly the same way as abdominal hysterectomy for uterine fibromata.

## CHAPTER VII

### ELECTRO-HÆMOSTASIS IN APPELDECTOMY

FINDING that the treatment of the pedicle of ovarian tumors with compression and heat applied with the electric current gave infinitely the best results, I employed the same method in appendectomy with equally fortunate and gratifying success.

That the same secondary troubles followed appendectomy as after removal of the Fallopian tube was apparent on reading the records of many surgeons. A. Laphorn Smith says that he had several cases from one to two years after the appendix had been removed, who were suffering from fecal fistula or pericæcal abscess. This is about the same as the testimony of Armstrong also, who reported in the *British Medical Journal*, October 9, 1897, that fecal fistula followed fifteen times in five hundred and forty-one cases. A. Laphorn Smith very clearly states that "because of the mucous glands which are imbedded in the mucous membrane of the appendix, it is quite as unsurgical to put a ligature around the base of the appendix a quarter of an inch from the cæcum and then cut the appendix off, as to propose to close an opening in the bowel by picking up the edges of the opening and tying a ligature around them, because this would simply bring mucous surfaces into contact, and, when the ligature has cut through or has otherwise fallen off, the secreting glandular surface would separate and the contents of the bowel escape. Those who follow this method may say that they cauterize the mucous membrane after cutting off the appendix, and not only

disinfect it but also destroy its secreting surface. But this, I maintain, it is impossible for them to do, because they manifestly can not reach the mucous membrane brought together by the ligature, and still less that part of it which lies below the ligature. If there were only one case of fecal fistula instead of fifteen in five hundred it would be worth while preventing it.

“The ideal method, in my opinion, and which I have followed in these cases, is for an assistant to hold up the intestine an inch on one side of the appendix, and, after tying and cutting the meso-appendix, to snip the appendix off even with the cæcum. The hole in the intestine is then sewed up with fine silk, care being taken to include the muscular coat. A director is then pressed upon the line of the suture until it sinks below the surrounding surface, when another row of sutures brings the peritoneal surfaces together. Such a closure will almost surely unite by primary union, doing away with all danger of fecal fistula or circumcæcal inflammation, by which the opening in the appendix is sometimes closed, and in which cases, although there is no fecal fistula, the patient is subjected to a good deal of discomfort while Nature is throwing out a layer of plastic lymph to seal the defective closure. Some authors recommend the peeling off of the peritoneal coat of the appendix, so as to form a cuff a quarter of an inch long, and then, after tying and cutting off the appendix in the manner which is condemned above, make up for the defect by sewing the peritoneum over the end of the stump. This is much better than leaving a sloughing stump free in the abdomen, but it is by no means as good as the method advocated above, in which no stump at all is left, and nothing but a fine, thin line of Lembert suture, which we know gives absolutely no trouble.”

This same method, described above, was fully given by Haggard, of Nashville, in a paper reported in the Transactions of the Southern Surgical and Gynæcological Association, at the tenth annual meeting in St. Louis, last

November. He summed up its merits as follows: "Total excision of the appendix, with closure of the hole in the head of the colon, was said to do away with the following dangers: (1) Subsequent perforation of the stump under the ligature from infection in its own cavity; (2) abscess of the wall of the cæcum from invagination of the infected stump; (3) continuance of the infected process from stricture in the stump between distal ligature and the proximal opening of the appendix into the cæcum; (4) imperfect invagination, with the incomplete drainage of the stump, on account of the cæcal wall being thickened and stiffened with inflammatory exudate."

I have not had an opportunity of examining, post mortem, the stump treated with the hæmostatic forceps, but have observed clinically that during the reparative process no immediate exudation can be detected; neither have there been any remote inflammations or exudates found on examination that caused pain or any other symptoms. The recovery has been complete and permanent. This is as might be expected, from the fact that the lumen of both the tubes and the blood-vessels is completely obliterated by compression and heat, and does not, in fact can not, reopen. That complete disorganization of the mucous membrane of tubes or vessels and permanent closure of their lumen are affected has been demonstrated in the several experiments detailed in the third chapter of this work.

This experience in ovariectomy and kindred operations led me to expect equally satisfactory results in appendectomy, and my expectations have been fully realized in practice. In fact, this method of treating the stump of the appendix has special advantages in being the only satisfactory way of controlling hæmorrhage in softened septic tissues, as well as closing the appendix itself.

In salpingectomy, ovariectomy, and appendectomy the surgeon often finds that the pedicle or point of separation is diseased, and the ligature is likely to cut the tissues if

made tight enough to close the vessels; and even if the mishap is avoided the stump is infiltrated with septic material, which causes trouble no matter how sterile or aseptically the ligature may be. With the hæmostatic forceps the vessels and lumen of the tube or appendix, as the case may be, are completely closed and the stump thoroughly dissected at the same time. I have had abundant opportunities to prove the advantages of this method of controlling bleeding vessels in pelvic surgery. I am now using it in other branches of surgery with equally satisfactory results.

The following case history is given as reported by clinical assistant:

W. S. P., aged thirty-two years; a New York merchant, of medium build, active disposition, neuro-sanguine temperament, regular habits; primary assimilation and ultimate nutrition good. Physical examination reveals apparently perfect health. Complaint is made for the past month of a dull ache in the right iliac region, usually merely annoying, but at times severely lancinating and markedly distressing. There are no other symptoms, either gastric or intestinal, except that the bowel is inclined to constipation.

A physical examination was easily made because of the laxity of the abdominal wall, and revealed a small movable tumor in the region of the appendix.

The patient's condition does not prevent his continuance in the regular duties of his business; yet, in view of his history of six other attacks, he seeks relief from the pain and mental disquiet by operative procedure.

The patient enjoyed good health until two years ago last Fall. The first attack was provoked, apparently, by a bath immediately after dinner. The local symptoms were typical of an inflammatory condition of the appendix vermiformis. The pain at first was general over the abdomen, beginning in the epigastrium, but soon became localized in the right iliac fossa. After four or five days of rest and medication relief was obtained, and the regular

business duties were resumed. In February, 1896, while suffering from a severe cold, a second attack prostrated the patient. At this time the pain was at once localized in the region of the appendix, and recovery under treatment was retarded for nearly two weeks. Again, in May, 1896, after partaking heartily of lobster, the patient was seized in a similar manner for the third time. On this occasion his condition was deemed so critical that he was advised to submit to an immediate operation. After nine or ten

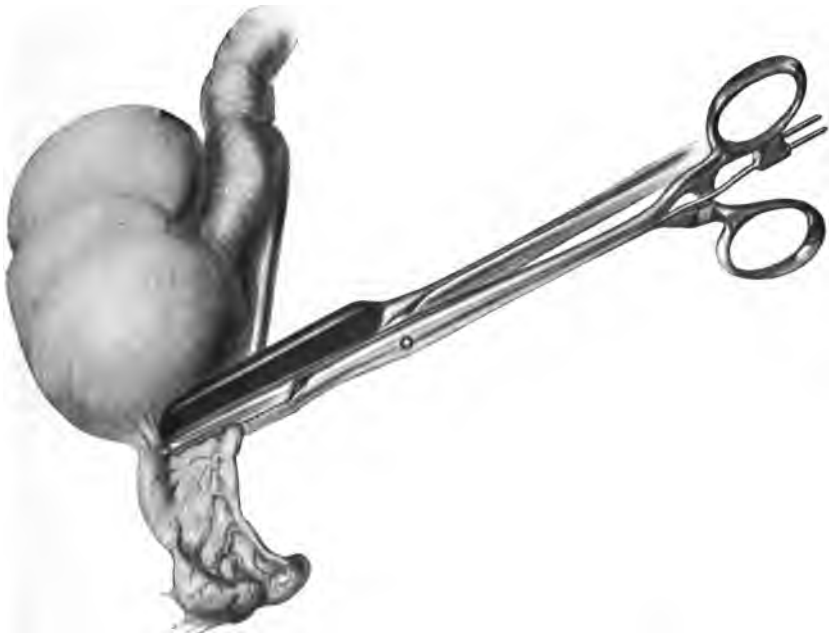

FIG. 38.—First seizure by forceps in appendectomy. The heating forceps grasps the meso-appendix, the shield forceps protecting the bowel.

days, however, he was relieved by medical treatment, and in a short while was able to attend to his business duties. Six months later, Thanksgiving Day, 1896, an extended railroad trip was suddenly interrupted by a fourth attack similar to the preceding ones. This was followed by a fifth in February, 1897, and a sixth in May of the same year.

The attacks were all similar in their onset, nature, and

course. The pain came suddenly, without any premonitory symptoms, and after the first time it was at once localized in the region of the appendix; there was no gastric disturbance except a slight nausea, nor intestinal, except tympanites; relief followed the exhibition of opium and local hot compresses. At the present time of comparative quiescence, and while he is yet in first-class condition to bear an operation, the patient has at last consented to the repeatedly advised surgical interference.



FIG. 39.—Completed treatment of mesentery in appendectomy. The scissors have bisected the seizure.

The operation was done January 11, 1898. For the first time in the history of appendectomy the method of operating with the electric hæmostatic forceps was followed. This departure from the current methods of ligature, suture, cauterization, invagination, and others is the logical outcome of the success of this practice when operating upon the pelvic viscera. All the other steps of the operation were such as are advised by surgeons generally. The incision was the ordinary one over McBurney's point, two inches in length. On inspection, both the appendix and the meso-appendix were found to be much enlarged and thickened, and superficially traversed by numerous dilated blood-vessels. There were no adhesions. The first grasp of the forceps was upon the meso-appendix close to its mesenteric attachment. (See Fig. 38.) A current which heated the forceps to 180° F. was then induced for half a minute. Upon removal of the forceps the tissues were found to be not charred but dried, having the appearance of white horny matter. Scissors were used to bisect this desiccated area. (See Fig. 39.) A second seizure was made upon

the appendix itself close to the caput coli, and the same current continued for ninety seconds. The forceps was

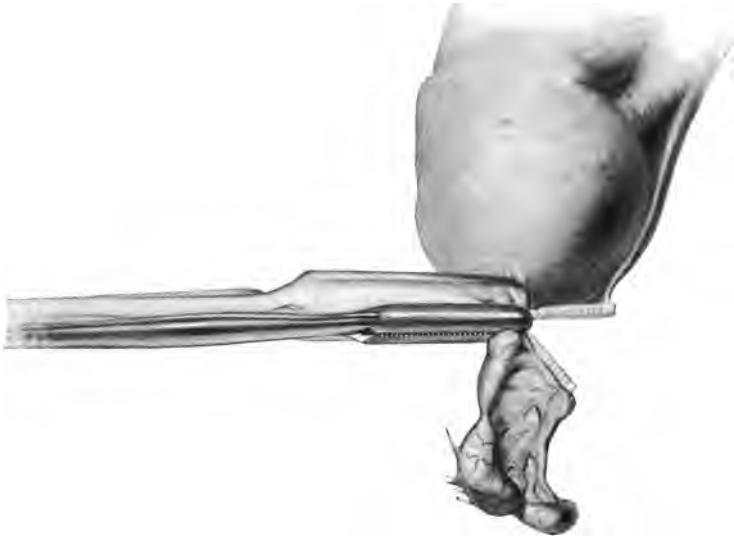

FIG. 40.—Second seizure of forceps in appendectomy. The dried surface of the first seizure has been bisected. The appendix is grasped. The shield forceps are shown faintly.

then removed and the tissue divided in the line of the desiccated area away from the caput. (See Figs. 40 and 41.) The same result was manifested. No charred tissue, no bleeding, and, more important than all, no escape of the contents of the appendix. The tissues had simply been dried out. Just at this point a rather violent attack of retching came upon the patient, which continued for nearly a minute, yet without inducing any change whatever in the stump. All the severe pressure and strain had not forced even a speck of blood or serum into the compressed area.



FIG. 41.—Stump after appendectomy, showing the two seizures.

The abdominal cavity was left perfectly free from any



foreign matter whatever. Sutures and dressings as usual. Time of operation fifteen minutes.

Anæsthetic, Schleich solution No. 3, nine drachms. Time for induction of narcosis, seven minutes.

The specimen measures seventy-five millimetres in length and forty-five millimetres in circumference, and is of an irregular S shape. The contents were about a drachm of pus, mucus, and broken-down cellular tissue. The meso-appendix is also much thickened, even to ten millimetres, and its greatest width is twenty millimetres.

A microscopic section made shortly after the operation, according to the Johns Hopkins "fifteen-minute" method, confirmed the diagnosis by revealing the typical structure of an old recurrent hypertrophied inflammatory change.

The convalescence has been unmarked by any complications due to the operation. When the sutures were removed after a week the parietal wound was perfectly dry and clean. At the close of another week the patient was sitting up, enjoying his newspaper and cigar, and was discharged from our care on the seventeenth day. He was seen eight months after the operation, and reported that his health had been perfect, and that he had had no pain or tenderness in the region of the operation.

I do not expect the judicious, cautious surgeon to accept the history of this one case as evidence of the superiority of this method to others that have been tried more fully; but my experience with it gives me full confidence that the verdict rendered by a full and fair trial will be favorable in the highest degree.

## CHAPTER VIII

### TREATMENT OF CANCER OF THE UTERUS BY THE ELECTRO-CAUTERY AND HÆMOSTASIS

DURING the past few years the treatment of cancer of the uterus has been vaginal hysterectomy almost exclusively, and upon theoretical grounds that appears to be the most appropriate way of dealing with this disease. Yet a careful comparison of all methods practiced leads to the conclusion that other methods of operative treatment are called for in certain conditions and give better results than any one operation.

The unprejudiced observer who has read the writings of Dr. John Byrne, and has seen his work and the results in amputation of the cervix uteri with the galvano-cautery, will be convinced that this practice is worthy of the surgeon's confidence. In very recent times, that is in 1895, Dr. Kelly and Dr. Clark reported a more radical method of abdominal hysterectomy for cancer, which, judging from their subsequent results, also merits attention and appears to meet the requirements in advanced cases of cancer of the uterus.

In my own practice at the present time I choose the operation best adapted to the stage, location, or condition of the disease in question. The condition or character of the disease and its location presents several forms.

In the majority of cases the disease begins in the cervix. In some the tissues around the os externum are first involved and the new tissue grows downward into the vagina. Fig. 42 illustrates this stage, in which only the

lower or vaginal portion of the cervix is involved. In other cases the disease begins in the mucous membrane



FIG. 42.—Malignant disease of cervix developing downward. *A*, seen in section; *B*, as seen through Sims's speculum.

within the cervical canal and dilates the cervix extensively before it protrudes into the vagina. (See Fig. 43.) A con-



FIG. 43.—Malignant disease of cervix beginning in cervical canal. *A*, seen in section; *B*, seen through Sims's speculum.

dition which resembles this is that in which the disease begins in the lower part of the cervix and extends upward

into the cervix while the portion that protruded into the vagina has sloughed off. In rare cases the disease begins in the body, or fundus uteri. In the first condition described amputation with the galvano-cautery ecraseur is called for. In the next state high amputation is required with the cautery knife. In the last condition mentioned, cancer in the corpus uteri, hysterectomy is the only operation indicated. These operations I shall describe in the order named.

*Amputation of the Cervix Uteri with the Galvano-cautery Ecraseur.*

Dr. John Byrne having been the first to operate successfully with the galvano-cautery and continuing to be the



FIG. 44.—Byrne's speculum for vaginal hysterectomy.

highest authority on the subject, I shall give his description of the operation. First, in regard to the exposure of the part to be amputated, Dr. Byrne uses his own speculum, which he describes as follows: "The instrument referred to is the speculum introduced and described by me about fifteen months ago, and a modification of which is here shown (Fig. 44).

"This speculum, it will be observed, differs none in principle from that previously noticed; and as to the several pieces of which it is composed, they may be considered the same, with one exception—namely, the frame on which the lower or perineal blade moves is much wider and a little longer, thereby affording more working space and

greatly facilitating operative manipulations. The foreshortened view in the above sketch will serve to explain more clearly the points of difference between this 'operating' and the ordinary speculum.

"Some advantages, however, will be found by having the intravaginal parts of this instrument a little longer—say half an inch—and from one quarter to three eighths wider than the ordinary size. I have also occasionally resorted to a piece of bent spring wire, to be introduced after

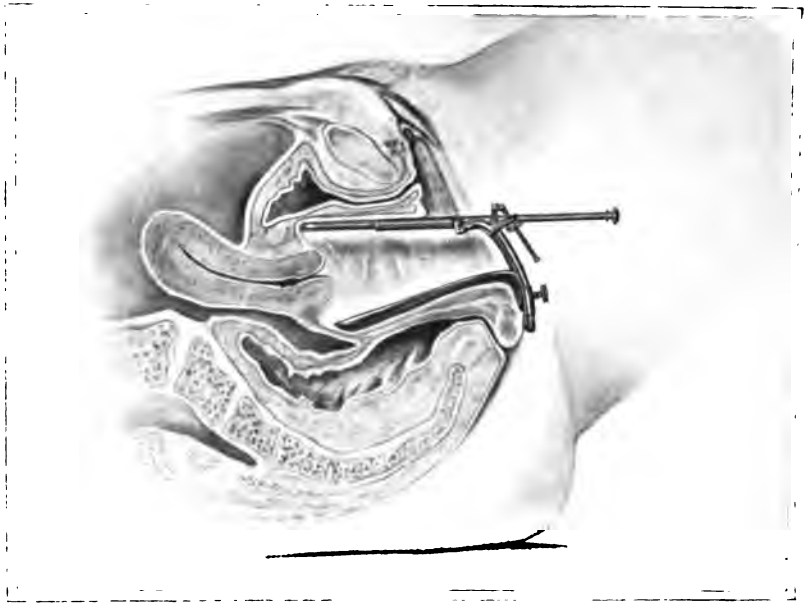

FIG. 45.—Byrne's speculum in position.

the speculum has been adjusted and the uterus fixed in position, for the purpose of still further separating the lateral walls. This, though by no means an indispensable requisite in any case, may nevertheless be made to render good service, under certain circumstances, and on this account I have given directions to have some such device supplied with each 'operating' speculum.

"Fig. 45 is intended to represent more clearly the principles on which this speculum is constructed and the *modus*

*operandi* by which the curved vaginal canal is not merely dilated but straightened by pressing back the perineum *below*, while the vesical wall is elevated *above*. The under blade, it will be noticed, is made to move in a circle in which the center is indicated by its point, so that the relations of the latter to the cul-de-sac, when the instrument is first introduced, does not materially change, no matter to what extent the perineal blade may be pressed backward. The various directions, too, in which the upper double rod may be made to move is a most important feature in the instrument; for, however displaced a uterus may be, more especially if anteverted, and provided no firm adhesions exist, there is no difficulty in bringing it into view, and so fixing it for examination or treatment.

“Fig. 46 represents an improved loop instrument.”

In operating for epithelioma of the cervix uteri characterized by exuberant outgrowths from a base, Dr. Byrne places the patient upon the back, exposes the cervix with his speculum and applies the platina wire loop as high up in the cervix as possible, and made moderately tight, the heat is applied and little or no contraction of the loop being affected for a few seconds, so that the tissues to be cut may be thoroughly cauterized.

Traction by the cautery instrument should, in all cases, be carefully avoided and the instrument kept steady and in



FIG. 46.—Byrne's cautery loop.

the same position from the beginning to the end of the operation.

The loop should be slowly and very moderately tightened just enough to follow up the tissues as they are divided by the cautery heat. When the tissues are firm enough to

stand traction, the part to be cut off should be seized with a forceps and traction made continuously while the amputation is going on. This leaves a dome- or cup-shaped stump, thereby removing the central tissues higher up.

When the portion of the cervix is conical and the cautery loop is difficult to apply, Dr. Byrne has employed the following ingenious method of operating, which I have taken from one of his histories of an operation :

“A large-sized rubber crochet needle, rounded at the end, was heated and slightly bent so as to accommodate itself to the curve of the sacrum and posterior contour of the tumor.

“A small hole was drilled transversely near its distal extremity, and at right angles with the direction of its curve, and through which a stout platina wire was passed

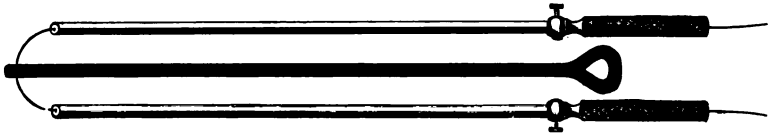

FIG. 47.—Byrne's special loop carrier.

half its length. The free ends of the wire were now passed through two copper tubes, each three sixteenths of an inch in diameter and eight inches long, and bent nearly the same as the rubber rod, Fig. 47.

“An anæsthetic having been administered, and the patient placed on her left side, the two tubes with the rubber rod between were carried behind the tumor as far up as deemed safe. The rubber support being now intrusted to an assistant, and maintained steadily in position, one of the copper tubes was carried around half the circumference of the tumor, the wire being pushed up, piece by piece, from below, and, when the center anteriorly had been reached, was so held until the opposite half had been encircled in like manner. Two small pieces of wood, each one-inch copper conductors, were one after the other slipped up so as to unite, yet insulate the latter.

“This being accomplished, the free ends of the platina wire were next passed through a modification of the loop instrument as shown in Fig. 48 and the copper conductors firmly fastened in the socket. All being now in readiness, the battery connections were made, when the heated wire cut through the rubber support and imbedded itself in the substance of the tumor.

“The rubber rod was now withdrawn, and the loop very slowly contracted, the time occupied in cutting through the whole mass being fully thirty minutes, exclusive of

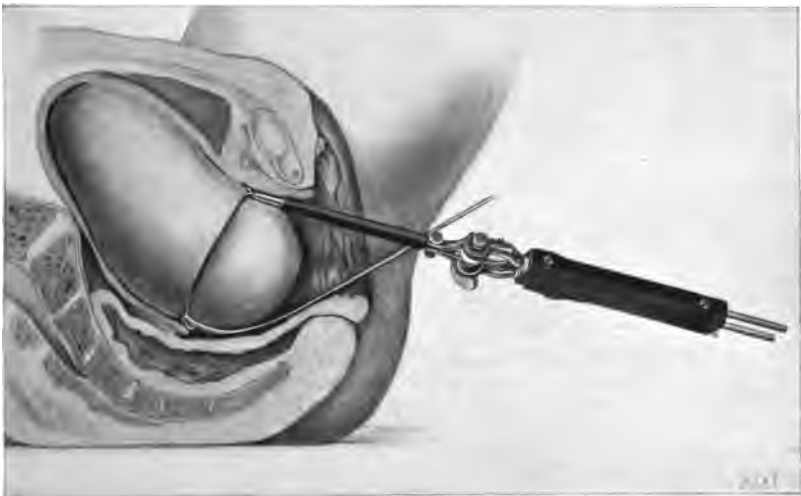

FIG. 48.—Method of passing loop around tumor.

necessary interruptions. There was no hæmorrhage from the stump, but the vagina was tamponed as a precautionary measure.”

#### HIGH AMPUTATION

In conditions admitting of high amputation, the following is the method usually resorted to: The uterus is to be exposed and the vaginal walls protected in the manner already described. The diverging volsellum (Fig. 49), after being passed well into the cervical canal, should now be expanded to a proper degree and locked, so as to afford complete control of the uterus during the entire operation.



By alternate traction and upward pressure of the uterus, an accurate idea may now be obtained as to the proper point to begin the circular incision, so as to avoid injuring the bladder or opening into the cul-de-sac of Douglas. As to the latter, however, should it be found that the disease has involved the retro-uterine tissues, and that its excision or destruction by the cauterly can not be effected without

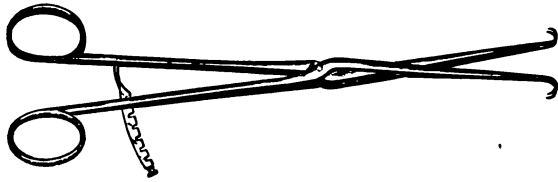

FIG. 49.—Diverging volsellum.

opening into the peritoneal cavity, there need be no hesitation in doing so. I have never known any harm to come from it whether it was done accidentally or by design. Should it be evident at the outset that the operation, in order to be thorough, must include a portion of the cul-de-sac, it will be better to make the line of incision anterior to this, until the cervix has been removed, and leave the incision of the retro-uterine parts *by the cauterly knife* to be the final proceeding. Under these circumstances all that will be needed will be an antiseptic tampon properly applied.

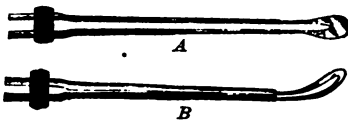

FIG. 50.—A, straight cauterly knife.  
B, curved cauterly knife.

In proceeding to make the circular incision the cauterly knife (Fig. 50), slightly curved *and cold*, should be applied close up to the vaginal junction, and from the moment that the current is turned on, should be kept in contact with the parts being incised (Figs. 51 and 52).

Before removing the electrode for any purpose, such as change of position, or altering the curve of the knife, the current should first be stopped and the instrument again placed into position while *cool* before resuming the incision. In other words, if *the knife, though heated only to a dull red*,

*be applied to parts at all vascular, hæmorrhage more or less will certainly follow ; whereas, the cool platinum blade being*



FIG. 51.—First step in high amputation of cervix. Making the circular incision.

*already in contact with moisture as the current is being transformed into heat, vessels are shrunk or closed even before they are severed.*



FIG. 52.—First step in high amputation of cervix. Making the circular incision (sagittal section). (Byrne.)

This is a very important point and should never be lost sight of in all cauterizing operations.

The circular incision having been made to the depth, say, of a quarter of an inch, it will now be observed that by increased traction the uterus may be drawn much farther downward, and by directing the knife upward and inward the amputation may be carried to any desired extent (Fig. 53).

In cases calling for amputation above the os internum, it will be better to excise and remove the cervix first; then, by dilating the upper canal sufficiently to admit the diverg-

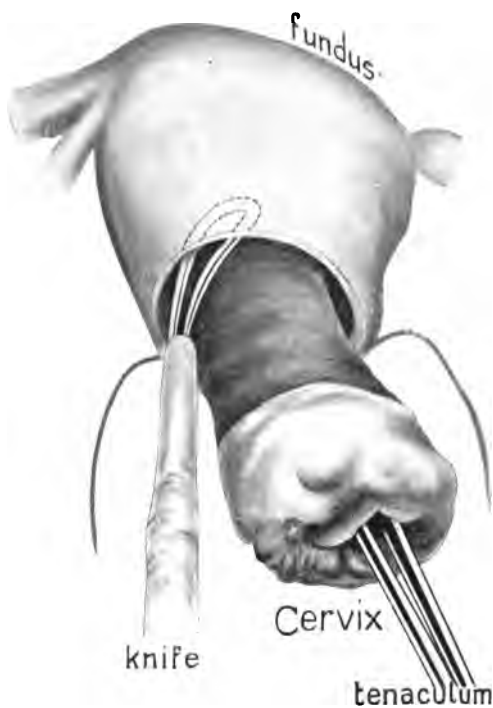

FIG. 53.—Second step in high amputation of cervix. Making the deeper incisions.

ing volsellum, once more proceed as in the first instance, taking care, however, to keep within bounds (Fig. 54).

It will be found that the cupped stump can now be drawn down and made to project as a more or less convex body.

In all cases the dome-shaped electrode (Fig. 55) should be passed over the entire cavity repeatedly so as to render the cauterization still more complete.

It is important to add that, in carrying the knife toward the *sides* of the cervix, circular and other arterial branches



FIG. 54.—Cervix having been excised, the dotted lines indicate higher incisions.

are likely to be encountered, and hence, in this locality particularly, a high degree of heat in the platinum blade is to be carefully avoided. As an additional security against hæmorrhage, the convexity of the knife should be pressed against the external surface of each particular section cut, so as to close the vessels more effectually. (Figs. 56 and 57.)

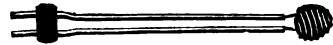

FIG. 55.—Dome-shaped electrode.

It is well to state that the metallic parts of the electrode for the distance of about two inches should be covered with a strip of thin flannel, so that the vagina may be protected from injury through the reflected heat.

#### VAGINAL HYSTERECTOMY IN CARCINOMA UTERI

Vaginal hysterectomy offers superior opportunities for the use of the hæmostatic forceps in arresting hæmorrhage. I have tried every known method of doing this operation,

and found them all objectionable, and so I was led to do the operation as follows: The general preparation of the patient is the same as for all major operations, but the cleansing and disinfecting of the vagina is difficult and requires special care.

If the body of the uterus alone is affected, the cervical canal must be washed out, packed loosely with cotton, and closed with a pair of forceps or with sutures. If the dis-



FIG. 56.—High amputation by one incision. (Byrne.)

ease involves the cervix, so that the cancerous mass protrudes into the vagina, it should be removed with the cautery or curette, and then the canal closed in the manner described. The object of this closure of the canal is to keep the parts clean and free from infection during the removal of the uterus.

It is always difficult to make the vagina and external genitalia aseptic, but in cancer of the uterus it is well-nigh impossible. On that account, I have removed the cancerous growths from the cervix preliminary to hysterectomy, and then made the parts as clean as possible.

This can be done without anæsthesia if the patient has ordinary self-control and the operator is dexterous. To disinfect the vagina and external genitals, I use when at hand an antiseptic solution of bichloride of mercury or carbolic acid and glycerin applied under high pressure from an atomizer. In that way the solution is forced into all folds of the tissues most effectively.



FIG. 57.—Charred cup-shaped stump after removal of cervix. (Byrne.)

Retractors should be introduced into the vagina, so as to expose the cervix and upper part of the vagina. The cervix should then be seized with a volsellum forceps and drawn outward and upward, and the posterior vaginal wall incised, the incision being semicircular and extending half around the cervix and outward half an inch or less, according to the size of the cervix. The peritoneum should be opened from the base of one broad ligament to the other. The anterior vaginal wall is then circumcised, and the uterus and bladder separated up to the peritoneum with the dry dissector or the finger. I prefer not to open into the peritoneal cavity in front until the broad ligaments are separated from the uterus up to and including the uterine arteries. The vagina is separated from the uterus with the



FIG. 58.—Cautery incisions in anterior and posterior vaginal wall.

knife, scissors, or galvano-cautery knife. I prefer the cautery. (See Fig. 59.)



FIG. 59.—Using the cautery knife in separating uterus from anterior vaginal wall.

The lower portion of the broad ligament is then seized with the hæmostatic forceps as close to the uterus as possi-



FIG. 60.—Seizure of lower portion of broad ligament.

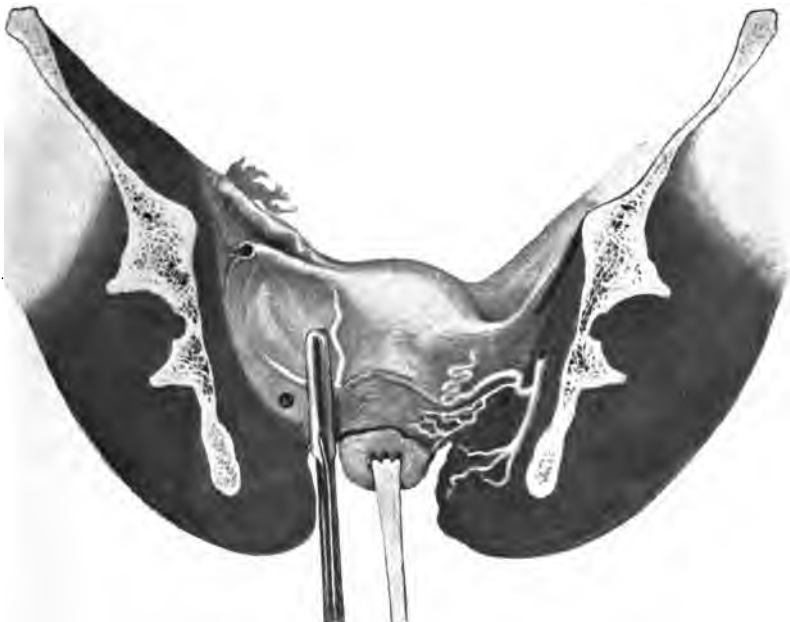

FIG. 61.—Diagram of seizure of lower portion of broad ligament. The forceps grasp the uterine artery. The black spot locates the ureter.



ble, and the heat turned on. The compression is increased while the heat is being applied. While the forceps is

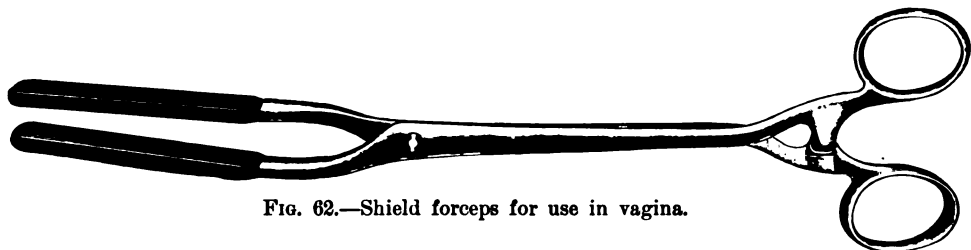

FIG. 62.—Shield forceps for use in vagina.

being applied to the broad ligament the bladder and anterior vaginal wall are held away from the forceps with a retractor to protect them from the heat. The tissues are protected from the heat posteriorly by means of the shield forceps shown in Fig. 62, whose shields cover the backs of the heated jaws, and are set at an obtuse angle to their



FIG. 63.—Diagram of seizure of upper portion of broad ligament when the uterus alone is to be removed. The uterine artery has been treated and cut across.

blades so that they do not interfere with the manipulation of the electrical instrument.

The shields are constructed of hard rubber, with a thin

metal core to give strength, and, being poor conductors of heat, effectually protect the adjacent tissues from injury.

A little practice is needed in order to know the length of time that the heat should be continued. When one is

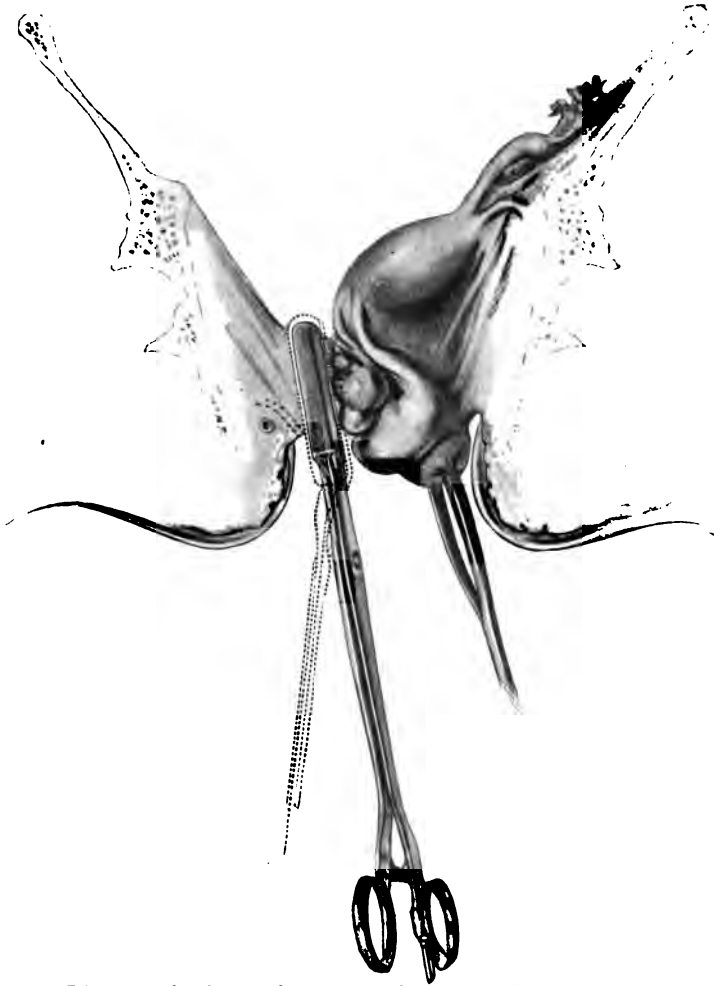

FIG. 64.—Diagram of seizure of upper portion of broad ligament when diseased tube and ovary are to be removed with uterus.

doubtful about this, the forceps may be removed and the parts inspected; and, if need be, the forceps should be re-applied and the heat continued long enough to obtain the desired effect. The ligament is divided with knife or

scissors between the forceps and the uterus as far up as the vessels have been closed. The lower portion of the ligament on the other side is treated in the same way. The uterus is drawn down, and the remaining portions of the ligaments are treated in sections until the uterus is completely freed. (See Figs. 63 and 64.) The operation may be briefly described by saying that it is performed in the same way as when forceps are used to control the bleeding (commonly called the French method), with the difference that instead of leaving the forceps on long enough for the compression alone to arrest the hæmorrhage (twenty-four or forty-eight hours), the heat completes the hæmostasis, and the forceps is removed at once.

After the uterus is removed a careful examination of the parts should be made, and if any portion of the broad

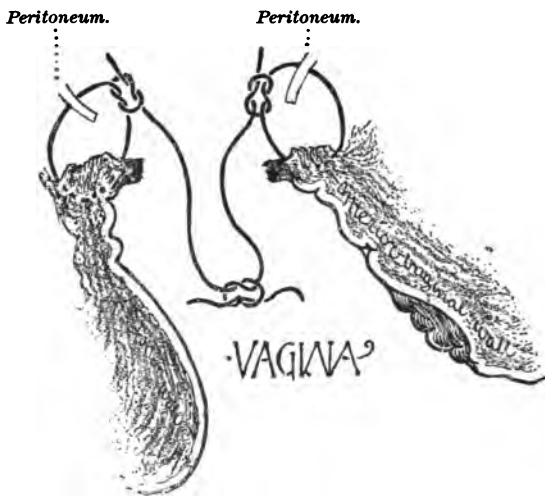

FIG. 65.—Diagram showing sutures ready to be tied.

ligaments shows that the disease has extended beyond the uterus, the suspected parts should be removed. This is done by seizing the stump with a fixation forceps and making traction enough to bring the part within reach and then applying the hæmostatic forceps outside of the traction forceps and desiccating sufficiently to destroy the diseased

tissue. The cavernous tissue is completely destroyed by the electric heat applied in this way, and the results are as good as if the part had been exsected. According to Dr. Byrne, cancer can be eradicated in this way at points in deep pelvic structures that can not be safely reached by the ordinary methods of extirpation.

The next step is to sponge the field of operation dry and clean, and then unite the peritoneum to the anterior and



FIG. 66.—Diagram showing sutures tied.

posterior vaginal walls with fine catgut sutures. The peritoneal cuts should be sponged clean. One end of each suture is then cut off and the remaining ends are tied to the opposite sutures, thus completely closing the wound, except in the center, where space enough is left to admit a small gauze drain. (See Figs. 65 and 66.) The vagina is loosely packed with gauze, and the operation is completed.

The advantages which may be fairly claimed for this method of doing hysterectomy are many in favor of both patient and operator. In the first place, and most desirable, it is a bloodless operation. Most of the patients having cancer are anæmic and can ill afford to lose blood. Then the operation can be done in less time than in any

other way, excepting by the so-called French method, which is most unsatisfactory in its results, and should not be considered in comparing the operations. Again, there is no pain and little if any constitutional disturbance. Besides, the time required for recovery is the shortest on record, and, judging by my own experience, the mortality is less than one half of one per cent. In addition to all this, the broad ligament stumps are reduced to the smallest size, the blood-vessels and lymphatics are completely closed, and hence the process of repair, which takes place by reorganization, is accomplished in very little time, and the thorough disinfection of the stumps by desiccation guards against reinfection and immediate recurrence of the disease. The time and taxation saved on the part of the surgeon can be realized only by one who has repeatedly operated in both this and other ways.

## CHAPTER IX

### THE ELECTRO-CAUTERY IN THE TREATMENT OF PELVIC ABSCESS AND DISEASES OF THE VULVA AND VAGINA

PELVIC inflammations ending in abscess were all treated by opening from the vagina in the times when salpingitis and ovaritis were not understood. At that date there were many cases requiring such treatment. But after the removal of diseased Fallopian tubes by abdominal section became established surgery, the vaginal route of getting at pus in the pelvis was given up. Within the past few years, and since vaginal hysterectomy has been perfected, vaginal section has become as popular as abdominal section was. I never gave up vaginal section for pelvic abscess in a given class of cases. I refer especially to pelvic cellulitis following parturition and secondary pelvic cellulitis caused by pyosalpinx with extensive adhesions, and in cases of general pelvic inflammation in which the pelvis is filled with the products of inflammation, so that the organs first involved, be they ovaries or tubes, and the site or depot of suppuration can not be removed by cœliotomy.

There are really three forms or conditions which call for vaginal section: the one a pyosalpinx, lying in the most dependent part of the sac of Douglas and bound down by products of inflammation which fill the upper part of the pelvis; the other where by ulcerative perforation the tube has opened into the cellular tissue of the broad ligament and there developed a cellulitis; and, finally, primary cellulitis following parturition or septic injuries of the cervix uteri.

*Treatment.*—The preparation for the operation and the position of the patient should be the same as in vaginal hysterectomy. The posterior fornix of the vagina being exposed by retractors, the vaginal wall should be divided with the cautery knife, heated while in contact with the tissues, throughout the entire width of the cervix uteri and outward on either side, in case the cervix is small, for half an inch. It sometimes happens that a divided vessel bleeds freely. That should be controlled by seizing the tissue at the bleeding point with a hæmostatic forceps and heating until the hæmorrhage is controlled. At this stage of the procedure an examination should be made for fluctuation or a soft part in the mass behind the uterus. If no such spot is found, a curved aspirating needle should be introduced to search for pus; when found, the needle should be left in place as a guide for the incision with the cautery. When the incision is made large enough to introduce the finger, a further examination should be made to determine whether there is one abscess or many. If the latter, the walls between them should be broken down and the cavity thoroughly washed out with carbolized water or such disinfectant as the surgeon prefers.

The wound should be enlarged in case it is not sufficient to secure free drainage. I prefer a roll of gauze, large enough to fill the wound and long enough to extend up to the upper portion of the abscess cavity. This drain of gauze should be removed at the end of twenty-four hours, and the cavity again irrigated and the smaller gauze drain used. This change of drains is most easily made with the patient in Sim's position. After this a double rubber drainage tube should be used and held in place by a suture, carried through the edge of the wound and the tubes. The cavity should be washed out daily until the sac contracts down, then the rubber tubes should be removed and a small pledget of gauze placed into the vaginal wound until the cavity is completely closed.

## CYSTS OF THE LABIA

Complete exsection is the proper treatment of the cysts that are quite frequently found in the labia. But this has proved to be very difficult in my practice, and I infer from reports that others have not been much more successful. I have tried in a great many cases to remove such cysts without rupture, but have invariably failed. The cyst wall is very thin, and so closely adherent to the surrounding tissue, especially at the deepest part, that complete enucleation is impossible, so far as my experience goes. Lack of success drove me to seek some more satisfactory method of operating, which I found in the following: In the large cysts that were near the surface, by making a free incision without wounding the cyst wall, I have succeeded in separating the cyst from the greater portion of its attachment; and by retracting the sides of the wound so that the base of the attachment was brought within easy reach, and then applying a narrow-bladed hæmostatic forceps to control bleeding and compress the tissue and form a stump, the stump is divided at the desiccated point, and the cyst set free thereby.

In some cases it is necessary to separate the adhesions in sections; that is to say, a portion of the cellular tissue is seized by the forceps, compressed and desiccated, and then divided in the center of the desiccation; another portion is treated in the same way until the cyst is completely liberated. All bleeding being arrested by the process, the wound can be closed with sutures, and healing proceeds without interruption as a rule. The cyst will be ruptured sometimes, though the greatest care be taken; then the next best thing to do is complete cauterization of the cyst wall. The wound is held open with forceps or tenacula and a fine cautery point or knife blade passed over the surface until every portion of the cyst wall is cauterized. The cauterization should be very superficial, but complete. If any portion of the cyst wall is left undestroyed, it will



continue to secrete and retard healing, or form another cyst.

When cauterization is employed, the wound should be left open until the charred tissue separates and is thrown off. When this separation takes place it is necessary to wash the *débris* away or sponge it out of the wound. The healing process goes on very rapidly under the crust of charred tissue, and when this separates, the closure of the cavity or wound is completed in a very short time.

This method of operating upon labial cysts involves much more time and trouble than the old way, but the comparatively little after-care required, the shorter time of recovery, and the relief from suffering, more than compensate both the patient and the surgeon.

#### CYSTS OF THE VAGINA

These cysts of the vagina are caused in some cases by a closing and distention of the vaginal glands, but they more frequently are developed from distention of Gärtner's ducts, a portion of one of them remaining patent.

This has been clearly pointed out by Amand Routh in his most interesting article in volume xxxv of the Transactions of the Obstetrical Society of London. Their recognition is not difficult, provided that a careful inspection is made of the vaginal canal. The treatment with the galvano-cautery is easy, and the results good. A free incision is made with the cautery knife through the vaginal wall, the cyst is laid open, and the cyst wall cauterized with the knife blade applied flatwise. The healing is accomplished in less time than when the incision is made with the knife; the bleeding vessels are ligated, and caustic is used to destroy the cyst wall.

Were it possible to remove the entire cyst intact by dissection, and to close the wound with sutures, that would be the most perfect procedure.

## VARICOSE VEINS OF THE VULVA

The veins about the vulva, like those in other portions of the body, may take on a varicose condition. This commonly occurs in those who have borne children; and, indeed, pregnancy appears to stand in a causative relation thereto, although cases undoubtedly do occur in those who have never been pregnant.

*Causation.*—Anything which obstructs the venous circulation will, by increasing the intravenous pressure, tend to produce this varicose condition, whether it be a pregnant uterus, a tumor, or, as mentioned by Winckel, the straining at stool, in case of obstinate constipation.

*Symptomatology.*—A patient may have well-marked varicose veins of the vulva, and yet be entirely unaware of the fact. Or a sense of heat and irritation may be experienced of so disagreeable a nature as to cause her to consult a physician, when the presence of varicose veins may be recognized. In still other cases the enlargement or swelling is so great as to attract her attention, though other symptoms may be absent.

*Physical Signs.*—Upon examination, in slight cases, the varicose condition of the veins is observed, and the swelling disappears on pressure, but returns immediately when the pressure is removed. However, in more aggravated cases, there may be so much tumefaction of the labia and other parts as to mask this peculiar condition of the veins. Holden describes a case in which a tumor existed as large as the head of a child.

The diagnosis in these cases is to be made by excluding other affections, such as hernia, hæmatocele, cysts, and cellulitis.

Surgical treatment should be limited to cases that are suffering, and in which there is danger of rupture from the extreme distention of the veins. Indeed, the only operative treatment advised is ligation and exsection of the veins.

This has not been very satisfactory, owing to very slow recovery.

The method of operating which I have adopted is as follows:

An incision is made through the skin over the most prominent part of the mass of veins. The skin and subcutaneous tissues are separated from the vessels with the scissors or dry dissector, until the parts to be removed can be drawn out of the wound. Then when possible the central portion of the mass is dissected out, leaving the veins attached above and below; the upper end of the veins is grasped with the forceps, compressed and heated until they are closed firmly. The lower end of the veins should be treated in the same manner, and the whole mass cut away. Any small vessels in the wound that bleed should be closed with the hæmostatic forceps, and the wound closed with sutures. While the hæmostatic forceps is being used, the shield forceps should be placed underneath to protect the tissues from the heat in the way described in treating the pedicle of an ovarian tumor.

If the mass of distended veins is not very large, they can all be seized in one grasp of the forceps, and treated in one piece and not in two sections.

This method of operating is so easily carried out, and recovery is so uneventful, that I have employed it in cases of lesser degree of development. I have the impression that the method might be employed in treating varicose veins of the legs.

**CONTUSED WOUNDS OF THE PUDENDUM.**—These are of two degrees of severity. A slight bruise, causing rupture of only a few small vessels (which very soon stop bleeding), gives rise to an ecchymosis, which quickly disappears. Occasionally inflammation follows, and an abscess develops, which is managed in the usual way. More severe are contused wounds which rupture the large vessels of the bulbi vestibulares or existing varicose veins of the labia, and produce pudendal hæmatocele—*i. e.*, an accumulation of blood

in the loose cellular tissue of the parts. The pathology of this injury is the same as that of bruises or contused wounds generally. There are laceration of the vessels and hæmorrhage into the cellular tissue.

In contusion of the pudendum two conditions conspire to make the injury grave in character—the large size of the vessels wounded, and the loose character of the cellular tissue, which admits of a very large accumulation of blood. The size of the hæmatoma depends upon the size of the vessels lacerated. In case the vessel is small, the bleeding may be controlled by the pressure from the blood in the tissues; but when large varicose vessels or the vessels of the bulb of the vestibule are lacerated, the size of the hæmatocele is very great. I have seen one nearly as large as the two fists.

The course and termination of the hæmatocele vary. If the blood-clot is small it may disappear by absorption without causing much discomfort, after the first pain of the injury subsides; but when the accumulation of blood is large, then inflammation follows which may terminate in sloughing or suppuration, and finally septicæmia.

*Symptomatology.*—The symptoms are pain following the injury, and then a feeling of fullness, heat, and sometimes throbbing. In one case that came under my observation the pressure was sufficient to prevent urination, and it was very difficult to pass the catheter. The attention of the patient being directed by the pain to the location of the injury, she discovers the swelling by the touch.

*Physical Signs.*—The physical signs vary in the different stages of the disease. At first the tumor is elastic and like a local œdema, except that it does not pit on pressure. After the blood has coagulated the parts are denser and slightly irregular or slightly nodular; discoloration of the skin occurs in twenty-four hours, or less. Œdema of the skin also occurs.

*Diagnosis.*—In regard to the diagnosis, it may be said that pudental hæmatocele can hardly be confounded with

any of the diseases of the pudendum except pudental hernia; but the mode of development and physical signs of the two affections are so unlike that the differentiation is easy.

*Causation.*—The causes of pudental hæmatocele are predisposing and exciting. Varicose conditions of the vessels, degeneration of the vessel walls, and marked engorgement from any cause which interrupts the venous circulation, render the vessels more susceptible to rupture when subjected to any injury.

Pregnancy predisposes to rupture of the pudental vessels, and labor is one of the most prominent of the exciting causes, but the present discussion of this affection is limited to causes occurring in the nonpuerperal state. The reader will find a very full account of this affection, as it occurs in labor, in a monograph by Prof. Fordyce Barker.

In regard to the exciting causes of the affection, it may be said, in brief, they are always traumatic. Difficult labor, direct blows, are the usual means by which the vessels are ruptured; indirect injuries—from a fall, for instance—might produce rupture of the pudental vessels, but I have not seen any case in which the injury was caused in that way.

*Treatment.*—When the patient is seen while the bleeding is still going on, a free incision should be made through the skin and the blood pressed out, the bleeding vessels seized singly or in mass with the hæmostatic forceps and closed by the pressure and heat. The wound is then closed with sutures.

In cases of longer standing in which a hæmatoma has been formed by the coagulation of the blood, the incision should be made with the cautery knife and the blood-clot turned out. Since the cellular tissue is infiltrated with blood, the whole coagulum can not be removed without starting bleeding. Hence it is necessary to control the bleeding vessels in the way described. The cavity being thus freed from blood-clots and the bleeding completely controlled, it should be packed with gauze and allowed to heal from below outward.

I have operated by making the incision with the knife and ligating the vessels, and am able to compare the old method with the new. The advantages are all with the new method of operating.

#### CARBUNCLE

All surgeons agree that free incision is indicated in carbuncle, but they admit that there are objections to the use of the knife, chief among them being the loss of blood that can ill be spared by the subjects of carbuncle, for they are always in a low state of general health.

There is, in my opinion, still another objection of equal importance, and that is the absorption of septic matter from the incised wound, which causes a further, and often dangerous deterioration of the general health.

These objections are met and the dangers avoided by using the cautery knife in making the incision. It is desirable to open a carbuncle before death of the deeper tissues takes place. At this stage of the disease one free incision through the skin, extending across the parts involved, is required. When the skin is divided the tension is usually sufficient to throw the wound open so that the incision can be continued down through all the tissues involved. When the carbuncle is large and induration well marked, two subcutaneous incisions should be made at right angles to the first. Clean gauze should be placed into the wound to keep it open and permit the serum, which soon begins to ooze from the tissues, to escape. There is no hæmorrhage if the incisions are made slowly and with a knife at red heat and the wound surfaces are rendered incapable of absorption. The pressure is taken off the blood-vessels, the circulation is re-established, and necrosis prevented. When necrosis has taken place the whole of the dead tissue should be exsected. That can be done by making a circular incision, retracting the edges of the incision in the skin, and with the cautery knife dissecting out all the necrosed tissue. It is necessary to keep within the line of demarcation be-

tween dead and living tissue. The separation of the core or necrosed tissue can be quickly done because the tissues are softened and bloodless. If by chance any portion of the dead tissue is left it can be easily seized and cut off. It sometimes happens that a large artery spurts, having been too quickly severed with the cautery knife. In that case it should be seized with the hæmostatic forceps and closed. A gauze packing should be loosely applied and left until it becomes saturated with the discharge.

Before the thin crust of charred tissue separates, the healing process is well advanced, so that an ordinary gauze dressing is all that is required to complete the treatment.

## CHAPTER X

### ELECTRO-HÆMOSTASIS IN EXTIRPATION OF THE MAMMARY AND LYMPHATIC GLANDS

I CONTINUED to use the ligature for controlling the hæmorrhage in extirpation of the mammary gland long after I had given it up in all my other surgical work. This was owing to the fact that the classical method had given general satisfaction. Occasionally there would be suppuration and delayed healing, but such imperfections were attributed to some surgical sin of commission or omission on the part of the operator and assistants. Then a rigid investigation would be made in order to discover the source of infection. Some possible cause of the objectionable effects were usually discovered, but in no case was the ligature found guilty or responsible, excepting on one occasion when there was cause for a suspicion that the catgut used was not aseptic. There was no reason in this to induce me to give up the ligature, so I continued to use it in this operation, until my first assistant said that he had forgotten how to tie a ligature, and, what was more to the point, the fact of having forgotten to provide clean, reliable catgut ligatures, suggested that the hæmostatic forceps should be used in the extirpation operation then on hand. Though believing that more time would be required to operate in this way, there was no apparent objection to trying. The operation was performed accordingly and proved to be so gratifying that I have followed this method ever since. Not that this method of operating has proved to be so much superior to the old way, but because it has been more satisfactory in being followed



by less pain and a shorter period of recovery, and saves all the trouble and time of obtaining reliable catgut ligatures.

There are so many ways of preparing catgut ligatures that one is in doubt regarding which to choose, and I find that many surgeons prefer preparing their own, or to have them prepared by assistants, rather than to obtain them from dealers in surgical supplies. This involves an amount of labor and trouble, and withal a feeling of doubt which the surgeon would gladly escape, I am sure. Perhaps this doubt regarding the sterility of catgut ligatures is personal, and others may have confidence in them when prepared as they direct or practice. I can only say that, not having time to prepare my own ligatures myself, I always have a fear that they may be imperfectly treated or contaminated in keeping. Therefore this made me the more willing to give up ligatures in removing the mammary gland, though, as already stated, I was fearful that more time would be required to control the bleeding with the new hæmostatic. My opinion on that subject was a mistaken one. In actual practice I saved time.

*Operation.*—The incision is made and the gland and surrounding adipose tissue exsected in the usual way. As the arteries are divided the assistant catches them with ordinary compression forceps to temporarily control the bleeding. When the whole breast is removed and all suspicious-looking parts of the fascia and muscle, each forceps is removed in the order of its application and the hæmostatic forceps applied exactly to the part from which the other forceps has been removed; the heat is turned on for a half or a quarter of a minute; the assistant holds the forceps while the heat is being applied, and meanwhile the operator applies the hæmostatic forceps to another artery and transfers the current from one forceps to another. The forceps is left on for a time after the current is discontinued. This is done because I found that the heat in the forceps was sufficient to continue the desiccating for some time after the heat supply was cut off. It will be seen from this

account that two or three arteries can be under treatment simultaneously and much time saved thereby.

In looking over the history of cases I find one of extirpation of the mammary and axillary glands performed in half an hour, and another in forty minutes. This compares very favorably with operations in the old way so far as time is concerned.

In extirpation of the axillary glands for cancer connected with disease of the breast, I have found this method of controlling hæmorrhage very satisfactory.

The mammary gland is first removed, then the incision is continued along the border of the pectoralis muscle; the glands and adipose tissue are then dissected away from the skin and fascia. Each gland is isolated with the dry dissector and fingers, and drawn away from the large vessels and nerves; in other words, they are made pedunculated. A narrow-bladed hæmostatic forceps is applied between the gland and the vessels and nerves, the heat used long enough to close the vessels, and then the gland is cut away. By being careful in separating the glands from the vessels in this way there is less danger of injuring the vessels, the large veins especially.

The results that follow compare favorably with those obtained by other surgeons, and are superior in several respects to those obtained in my own practice by operating in the usual way. There is less pain and the healing process is completed in much less time. This can be best illustrated by the following notes of a case recently treated: The patient was operated upon years ago at different times for laceration of the cervix uteri, laceration of the pelvic floor, and rectal hæmorrhoids; subsequently one of her ovaries was removed by vaginal section; last of all her right breast was extirpated for cancer. Her experience certainly qualified her to judge of pain after surgical treatment. Her testimony regarding the last operation was that she had no pain whatsoever. There was no rise in temperature, and the pulse after her recovery from the anæsthetic remained

normal throughout her convalescence. Her appetite and nutrition were normal, and she slept well. On the morning of the fourth day she left her bed and was about her room. The sutures were removed on the seventh day, all of them coming away dry and without any bleeding. Two drops of clear serum escaped from the track of one suture after its removal; union was complete and perfect, and there was no swelling or induration of the parts. There was no traction upon the edges of the wound. A thin layer of sterilized cotton was placed over the chest and a bandage applied. This dressing was removed on the twelfth day and was found to be dry and clean. At that time the process of repair was complete. There was no tenderness anywhere, the skin was everywhere movable upon the thorax to a slight extent, and the arm could be moved in every way without pain. Such perfect healing of the skin incision and between the skin and deeper tissues of the thoracic wall I have never known to take place in so short a time when a number of ligatures were used to control the bleeding.

A comparative study of this and others operated on in this way indicates that the process of repair is simpler and is completed in less time than in cases in which ligatures have been used, and have to be disposed of by absorption or becoming encysted. Therein the clinical phenomena and the laboratory experiments coincide, and prove as clearly as need be that the use of the hæmostatic forceps has just claims upon the surgeon's confidence in regard to the repair of wounds.

Having found that extirpation of the breast is a rather long operation, owing to the time required to arrest the hæmorrhage, I was of the opinion that the new hæmostatic would prolong the operation still more; but, as already hinted at, less time was required to close the arteries completely and leave the wound so dry that no drainage was required. More time was needed to close the large vessels than if the ligature had been used, but the small vessels, ignored by some operators, which I always take pains to

stop, were managed in less time, so that a complete drying state of the wound was obtained in as little or even less time than I had ever employed while operating in the old way. This may be made clear by giving an illustrative case: The patient had carcinoma involving about two thirds of the left mammary gland. The tumor was not large; the skin was not perceptibly involved, but the axillary glands were very large, indurated, and matted together, forming one irregular mass a third of the size of the tumor in the breast. I do not remember having seen the axillary glands so extensively involved in connection with so moderate an advancement of the disease in the breast.

By an unexplained omission the blood had not been examined, and I was surprised by the discovery, during the operation, that she was hæmorrhagic. There was no great vascularity apparent, and I was not expecting any trouble with the hæmorrhage, nor were the principal arteries large, but the smallest vessels kept on bleeding so that I was obliged to close them after the removal of the breast and before clearing out the axillary glands. Troublesome hæmorrhage was anticipated in removing the lymphatics in the axilla, but I was pleased to find that I had less trouble than was expected. Some bleeding was avoided by not extending the incision of the skin as far upward as usual, and there being no adhesions of the parts to the muscles, there was no bleeding from small muscular arteries such as were so troublesome in the breast part of the operation. The main arteries were treated in the way described in the first operation given, and the small ones were caught in the small artery forceps (which was kept heated continuously) and held for the few seconds required to stop them. The small arteries in exposed muscles and in the skin were the most difficult to manage; still they were all closed and the wound made quite dry, far more so than I could have made it by using ligatures. The surface of the wound was freely studded with the stumps of closed vessels, but was smooth and clean compared with what it would have been

if I had used ligatures. How long it would have taken me to operate if I had used ligatures I do not know, but I am very sure that I could not have so completely arrested the hæmorrhage in a bleeder like that one by ligation, and I have never been able to do such an operation in less than forty-five minutes, the time required in this case.

The incision in the skin was made short to avoid hæmorrhage and to save the necessity of many sutures, the latter giving great advantage, because needle punctures bleed freely in such patients. Only two sutures were employed, and the remaining part of the wound closed with adhesive strips. The healing was without interruption. There was no suppuration and only a very little escape of pinkish-colored serum during the first day after the operation.

#### EXTIRPATION OF DISEASED LYMPHATIC GLANDS

The affections of the lymphatic glands characterized by enlargement that call for extirpation are not to be considered here. The classical method of exsection gives entire satisfaction no doubt, but in scrofulous and tubercular disease of the glands in the inflammatory stage, especially when there is suppuration, much more gratifying results can be obtained by operating with the galvano-cautery. At least, such has been my experience.

The method of operating should be adapted to the condition present in an adenitis in the first stage—that is, before suppuration has taken place. The incision is made with the cautery knife through the skin, and the adhesions of the gland to the neighboring parts separated by dry dissection; vessels that are large enough to bleed are closed with an application of a hæmostatic and divided. Very often the main artery which supplies the gland is imbedded in a mass of exudate and cellular tissue from which it can not be isolated. In that case the whole mass should be treated with the hæmostatic forceps and the gland set free by dividing the desiccated portion of tissue containing the

vessels and nerves. Small bleeding vessels that are found should be closed, and any exudate or products of inflammation that have been left should be dissected out and the cavity loosely packed with gauze and an aseptic dressing applied.

At the end of twenty-four hours the gauze packing should be removed and the wound redressed. It is not necessary to introduce any drain afterward at the second dressing, unless the wound is very deep; the incision in the skin having been made with the cautery, the surface wound will not heal before the cavity is closed.

Suppurating cases are operated by first opening into the abscess with the cautery knife and removing the gland tissue and inflammatory products with a curette, thoroughly washing out the cavity and drying it, and then superficially but completely cauterizing the surface; finally packing and dressing, as described above.

This method of operating in suppurating tubercular disease of the glands gives superior results, as indicated by a speedy and complete recovery. Making the incision with the cautery knife prevents hæmorrhage and reinfection, and the cauterization of the cavity surface arrests the suppurative disease so that recovery promptly takes place, instead of continued suppuration and extension of tubercular infection, which so frequently follows after evacuation by curetting alone, and finally the scar is smaller than that which follows the usual way of operating.

## CHAPTER XI

### ELECTRO-HÆMOSTASIS IN EXTIRPATION OF TUMORS OF THE BLADDER

IN times past I had considerable experience in the treatment of neoplasms of the bladder, according to the methods given by the best surgical authorities.

Either vaginal or suprapubic cystotomy was performed, the choice between the two avenues of approach being determined by the location of the growth to be removed. When the part to be removed was reached, it was cut off with the scissors or removed with the curette, and the hæmorrhage stopped by ligation of the vessels or the application of such styptics as hot water, persulphate of iron, or acetic acid. The bladder was drained until healing took place. I never cured a case in this way, and I am not sure that the life of the patients was prolonged by the treatment. In fact, in two of my patients life was probably shortened, though great relief was given by the treatment.

With such discouraging results before me I determined to try the clamp and cautery method of operating.

The first removal of a neoplasm, supposed to be malignant, from the bladder with the clamp and cautery was one in which I was able to make an accurate diagnosis of a tumor, about an inch and a half in diameter, on the upper part of the anterior wall of the bladder. The patient had for months suffered almost continuously from hæmaturia. I made a vesico-vaginal fistula by dividing the tissues with the knife and scissors; then, by having pressure made above the pubes and raising the vaginal wall, brought the tumor



down to the vaginal fistula, and succeeded in drawing it through into the vagina, and with it, of course, a portion of the anterior wall of the bladder. I clamped the base of this growth with the forceps and then cut it off with the cautery, and, applying the cautery to the blades of the forcep, desiccated the portion within the grasp of the forceps, most of which was normal mucous membrane; the forceps was then removed, the bladder thoroughly washed out, and the vesico-vaginal fistula closed with silk sutures. The bladder was drained with a retained catheter for twenty-four hours after the operation, and then catheterized every four hours for three or four days. The patient made a complete recovery. Having succeeded so well with the clamp and cautery, I was led quite naturally to expect that still better work could be done with the hæmostatic forceps; and soon after that instrument was devised, I found an opportunity to try it, and it came quite up to my highest expectations.

This, in brief, is the story of the evolution of the present-time operation for neoplasms of the bladder.

#### EXTIRPATION OF NEOPLASMS OF THE BLADDER THROUGH A VESICO-VAGINAL FISTULA

Single tumors of small size attached to the bladder wall at any point, excepting the middle of the posterior wall, can be removed through a vesico-vaginal fistula, and it is the best way of operating.

The patient is placed in the Sims position, and an opening made in the median line large enough to permit the tumor to pass through. The vaginal wall is pressed upward with a long forceps, the open blades of which are placed against the edges of the fistulous opening. An assistant makes pressure over the hypogastric space to crowd the bladder down to the opening, and force the tumor out into the vagina. The operator holds the forceps which supports the vaginal wall in his left hand, and aids in the delivery of the tumor with a small sponge in a holder. The



sponge is used instead of the traction forceps to aid in the delivery of the tumor, as the tissues are always friable, and the forceps would tear them. When the base of the tumor is thus brought into view, the hæmostatic forceps is applied, and a thin shield adjusted to prevent the heat from injuring the bladder or mucous membrane, and also keep the partially inverted bladder from getting away from the operator. It is better to include a portion of the mucous membrane of the bladder in the hæmostatic forceps than to run the risk of letting any part of the diseased tissues escape. The heat should not be above  $175^{\circ}$ , but should be continued for two minutes and a half; and very little traction should be made on the forceps, because the tissues are friable and easily torn from their attachment to the bladder wall. When such a mishap occurs, the bleeding should be controlled by singeing the points that bleed with a small hæmostatic and closing them, or a cautery below red heat may be used.

The tumor is cut off close and the forceps opened enough to loosen their hold, and the stump is permitted to escape by slipping off the forceps as one would take a ring off the finger. In that way the delicate stump is not torn. Formerly I washed out the bladder before closing it, but that is not necessary.

The opening in the bladder is closed with silk sutures, and drained for a day or two with a catheter of soft rubber. Fig. 67 shows the tumor crowded out through the opening, with the forceps and shield in place.

*The Suprapubic Operation.*—Large and multiple neoplasms and those inhabiting the lateral walls and base of the bladder can be successfully removed only through the suprapubic opening.

In addition to the usual preparation for the operation the bladder should be thoroughly washed out and disinfected, using every care not to start bleeding. A mild solution of acetic acid is the best, as it is a good styptic and a fair disinfectant. The bladder should be filled but

not be distended with air or water, and kept so until the opening is made. Distention invariably causes hæmorrhage less or more, and complicates the operation.

The opening should be made as large as possible; the edges of the wound held apart with retractors, and the interior illuminated with direct or refracted light. The bladder is emptied with the catheter and then sponged dry. In case there are a number of growths situated at different parts of the bladder each one is caught at its base with the hæmostatic forceps, treated, and cut off. Single

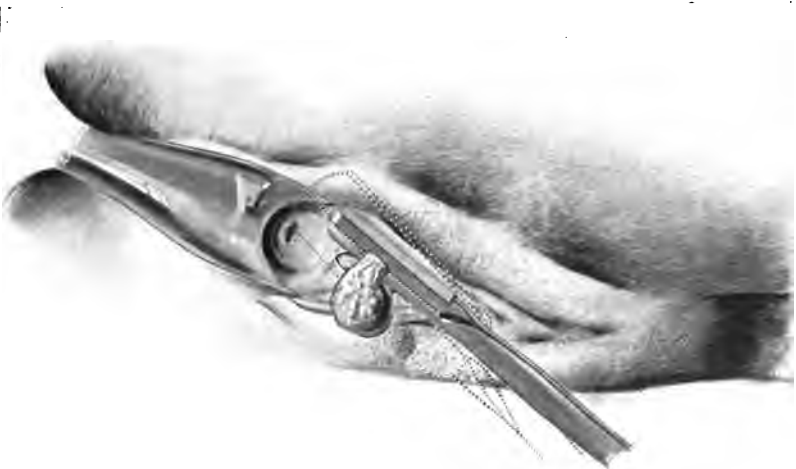

FIG. 67.—Bladder tumor drawn out through a vaginal incision. The hæmostatic clamp grasps the pedicle; the shield forceps is shown by dotted lines beyond the clamp. The patient is in the Sims's posture.

large growths with broad attachments are treated in sections; that is to say, a portion, such as can be grasped at once with the forceps and treated, and then another, until the whole is exsected. Long retractors are used to keep the bladder walls away from the hot forceps in cases where there is not room enough to use the shield forceps conveniently. Fig. 68 illustrates this part of the operation.

When the disease has involved the muscular wall of the bladder (a condition found only in cancer) the entire

base of the tumor, including the bladder wall, should be removed. That is done by first removing the tumor which projects above the surface, then seizing the stump in the middle, and by traction drawing it inward and upward until the hæmostatic forceps can be applied and the whole



FIG. 68.—A pedunculated growth of the bladder clamped by the hæmostatic forceps; the bladder wall is protected by the shield forceps. On the anterior bladder wall the stump of a previously treated tumor is shown.

of the diseased part removed ; or, if that can not be done at once, it can be done in sections. This radical treatment of advanced cases should not be undertaken if the disease involves or goes close to the ureters or urethra. In the majority of cases the bladder should be drained from

above until healing is completed; but if the base and fundus are normal the wound may be closed and drainage made with the catheter.

The stumps are thrown off in course of the healing, and should be washed out. Any scrap of dead tissue left would form a nucleus for a calculus.

There being no hæmorrhage in operating in this way, the procedure is easily accomplished compared with the old way.

The wounds left to heal are very small, and the stumps being glued together, as it were, become almost completely healed before the desiccated portions are thrown off. It may be said that the bases from which the tumors were removed heal under a scab, thus avoiding ulcerating surfaces that are slow to heal.

By removing single small neoplasms in this way the opening in the bladder can be closed immediately, and the treatment completed in one operation. The thoroughness of the operation prevents or delays the recurrence which followed sooner or later in all my cases treated according to other methods. The following case selected from a number illustrates the clinical history and treatment of this class of affections:

Mrs. H. H. C. came under observation in January, 1892, saying that for some little time past, following convalescence from a severe attack of *la grippe*, she had been noticing blood in her urine. At first but little attention was given to this condition for she never suffered any pain; but during the past six months she became aware of feeling easily fatigued, and felt that she was "running down"; at the same time the hæmaturia was becoming more and more pronounced, until for the six weeks prior to her admission the urine constantly showed the presence of large amounts of blood.

The hæmorrhages were at once controlled by irrigations with acetic acid and the administration of instillations of fifteen drops of fluid extract of *hydrastis canadensis* before

meals. In a few days a thorough cystoscopic examination could be made. The bleeding was traced to a papillomatous growth in the upper left lateral quadrant of the bladder. The tumor was removed on January 28th, by way of the vagina, with the clamp and cautery. The fistula was closed at once.

The recovery was favorable. Some large granules of phosphates were found in the urine for a few days after the operation. When the sutures were removed in the following week the fistula had closed, except a small opening of the mucous membrane of the vagina in the lower angle. This was obliterated within the week, and the patient left the sanatorium nine days later.

In the fall of 1894 the patient returned with a history of entire relief until a few months ago; but that now her urine again shows some color almost constantly, and at times is decidedly bloody. She has been well otherwise except for a severe siege of typhoid fever, but this did not seem to have any influence upon her bladder. She is free from pain, retains her urine the usual length of time, and feels just as she did at the time of the previous operation.

The cystoscope shows a possible return of the neoplasm, but the area is darker in color and looks more like a deposit of urine salts on the scar. The examination was not entirely satisfactory, as there had been bleeding the day before; so the bladder was irrigated and prepared for another examination. This time the cystoscope reveals several neoplasms near the fundus; they are smooth, lobulated, of a grayish color. There is also a body in the base of the bladder, round and like a stone, but it does not give the characteristic click when touched with the sound. When the bladder was opened this area was found to be a deposit of urinary salts on a soft papillomatous base. A suprapubic cystotomy was done, and a number of small papillomatous tumors removed by the new method. The patient was discharged after an uneventful recovery.

Six years after the first operation the patient once more

returns for relief. But this time the history is very different. She has been in almost constant pain for a year. At times there would be a temporary amelioration of her condition, but for the greater part of the period she has been most at ease only when lying on her back. Micturition has been normal, but frequent, and at times would be preceded, again followed, by sharp spasmodic pains. The history is meager as to the appearance and character of the urine. It is thought that two small gravel stones were voided in the fall of 1895, yet the diagnosis of calculus was not made by the physician in charge. The case was treated as simple catarrhal cystitis. The only other important incident observed was an occasional incontinence.

A vesical calculus was discovered at once, and the diagnosis confirmed February 15, 1898, by doing a vaginal cystotomy and removing a large stone. The weight is fifty-six grammes; it is fifty-five millimetres long, thirty-five millimetres wide, and one hundred and ten millimetres in transverse circumference. The shape is that of a slightly irregular ovoid flattened at one of the poles, and is fairly smooth. On section only a few lamellæ are seen, and these are toward the periphery. The nucleus is distinguished from the rest only by being imbedded in a deeper mass of more porous matter. Chemical analysis places it in the class defined by Hoffman and Ultzman as "metamorphosed" stones, for it is composed of earthy phosphates forming a quite homogeneous and porous mass.

Convalescence was rapid; there was no return of the pain; and the urine showed a rapid decrease in crystalline deposit and the usual evidences of bladder irritation caused by a calculus. The wound was left open to insure perfect drainage for a time. It would have closed of its own accord had it not been for a prolapsus of a portion of the mucous membrane into the lower angle of the opening.

The after-treatment has consisted in daily irrigations, and for a week maintaining continual drainage during the night by catheter. Within a fortnight the patient was

able to sit up several hours daily without any discomfort or any return of her former ill feeling or symptoms, and about a month after the operation returned to her home.

The interest in the case centers largely in there being no recurrence of the former growths, in the age of the patient (she is now sixty-three years of age), in the size of the stone, its rapid formation, and that its formation was due to some scrap of dead tissue that remained after the second operation.

After remaining at home for two months, during which time she was well and regained her strength, she returned, and I closed the small fistulous opening that remained. Before operating to close the fistula a most rigid examination of the bladder was made, but no foreign body was found, and not the slightest evidence of a recurrence of the papillomatous growths. It is now nearly a year since she went from under my care, and she is perfectly well in every respect.

#### THE TREATMENT OF ULCERS OF THE BLADDER WITH THE GALVANO-CAUTERY

I was induced to use the galvano-cautery in the treatment of ulcers in the bladder by a somewhat curious experience.

A girl nineteen years of age came to my clinic suffering from hæmaturia, which had troubled her for over two months. Her health was good and the urine normal, excepting the blood which it contained. I first made sure that the blood came from the bladder, and then put her upon the usual internal remedies for hæmorrhage of the bladder, but with no benefit to her. A bimanual examination of the bladder gave negative evidence, but it increased the hæmorrhage for a time. A solution of acetic acid, which was used to wash out the bladder, controlled the bleeding long enough for a cystoscopic examination. On the lower part of the posterior wall I found a whitish-gray colored body about three eighths of an inch in diameter,



surrounded by a border of papillomatous or granulation tissue very red and vascular. A diagnosis of calculus partially encysted was made upon the physical signs obtained with the cystoscope. The use of the sound and a bimanual examination gave no evidence confirmatory of the diagnosis. The bladder was opened through the vagina, and I found that the object which appeared to be a stone was a thick deposit of urine salts upon an ulcerated surface. The deposit and soft vascular tissue around it were removed with a curette and pressure made upon the raw surface with a sponge until the bleeding ceased. A small galvano-cautery was applied—at dull red heat—to the whole surface long enough to destroy the whole of the diseased tissue and form a thin dry crust over all.

The wound in the vagina was closed, and the bladder drained with a catheter for three days. After that the patient was made to urinate every four hours for the remainder of the week. About that time a number of blackish particles were passed with the urine—the *débris* of the cauterized tissue. For several days thereafter the bladder was washed out to make sure that no bits of dead tissue remained to cause the formation of a calculus.

The patient made a good recovery, and was well a year later, at which time she was and gave promise of continuing free from recurrence of the affection.

The benefit derived from the cautery in this case induced me to employ the same treatment in cases of ulceration of the bladder. In chronic cystitis of long standing, especially in aged women, an ulceration occasionally occurs generally at the base of the bladder. These are seldom cured by instillations or caustic applications. This was another inducement to try the cautery. The diagnosis and the localization of the ulcer is made with the cystoscope. The operation or application is made by placing the patient in the knee-chest position, introducing the largest endoscope that can be used with safety, and bringing the diseased part into the field of vision and applying the cau-



tery. Ulcers of considerable size can not be all seen at once, and so one requires to cauterize portions at a time, doing one part and then another till the whole is treated. Considerable experience and practice is necessary in order to operate successfully, but the benefits derived compensate fully for all that.

## CHAPTER XII

### THE ELECTRO-CAUTERY IN THE TREATMENT OF URETHRAL AFFECTIONS

THE diseases of the urethra in which the electro-cautery is most effective are neoplasms about the meatus, urethritis, narrowing of the meatus, either congenital or acquired, and inflammation of the urethral glands and follicles.

In regard to the pathology of these neoplasms at the meatus urinarius, there are two forms to which I wish to call attention. One, the rarest, is *angioma*, caused usually by malnutrition and deranged circulation. These growths closely resemble rectal hæmorrhoids in both the pathology and the causes which produce them. The other is a *proliferation of tissue*, caused by a chronic inflammation of the glands or follicles in the vaginal side of the urethra. Both varieties have been known as vascular growths of the meatus or caruncle.

The diagnosis is of course easily made when the disease is confined to the exposed portion of the meatus, but when these growths are within the urethra the diagnosis can be made only by the use of the endoscope. I may state in passing that many do not use this instrument for diagnostic purposes, owing to its being rather inconvenient and requiring experience in its use. To meet that, I find in many cases a diagnosis can be made by exclusion. Displacements and dislocations can be detected or excluded by the touch and sound, and cystitis can be disposed of by frequent and careful urine examinations.

Most important of all in this connection is the cysto-

scope, which is so valuable in detecting or excluding diseases of the bladder which simulate in a marked way certain diseases of the urethra, but this instrument is not always at command. I find that the differential diagnosis must be made by the majority of practitioners, if made at all, by examinations of the urine and from the symptoms. When it is determined by exclusion that the disease is confined to the urethra, the question rests then between inflammatory affections and displacements and dilatation. The latter can be detected, as before stated, by the touch and sound.

To return to the treatment of neoplasms, the indications are to thoroughly and completely destroy the diseased tissue and nothing more. To do this with caustics in the way usually commended is impossible—at least I find it so. The diseased tissue can be destroyed, if not by one, by several applications; but the line of demarcation between the normal and abnormal tissue can not be clearly and accurately drawn, and the action of the caustic limited to that one part. After the eschar separates the surface left to heal is large, painful, and tender, and during the healing process there is great liability to the recurrence of the original disease. This is one of the reasons for the frequency with which these growths return, as noted by all writers on the subject. Exsection is a more surgical method which gives better results when well done than caustics; but unless sutures are used to close the wound the healing is slow and uncertain, especially if the urine is in any degree morbid.

The galvano-cautery fulfills all the requirements perfectly and completely. There is less pain in its use. Healing is more rapid, and there is less likelihood of the disease returning.

The cautery instrument which I employ is the fine point. (See Fig. 75.)

A larger cautery can be used with advantage in removing large neoplasms, but for all general purposes the small

one is the best. I may here mention the fact that it should be brought to the desired heat before applying it to the tissues, and then after making one incision or application it should be withdrawn from the tissues and reheated. This is necessary, because the moment this fine point is brought into contact with the tissues there is so much leakage of the current that the cautery very soon cools off a little. I mention this because I have so often seen the inexperienced, who were not aware of this fact, bothered by the cautery cooling and not doing its work fast enough.

The method of operating for angioma at the meatus urinarius is as follows :

The neoplasm to be removed is seized by narrow-bladed forceps at the junction of the normal and abnormal tissue ; the forceps is closed and locked and the neoplasm cut off. The current is turned on and continued to heat the forceps enough to desiccate, not char, the tissues in its grasp. When this is accomplished the forceps is carefully removed by first unlocking it, then rocking it gently, so as not to pull the pedicle or stump apart and start bleeding. If the work is well done, the thin stump of desiccated tissue will project from the surface of the mucous membrane. If there is any portion of the diseased tissue left, it should be touched with the cautery.

It is important that the patient should not urinate for several hours after the operation, because if the stump can be kept dry for a time it will not spread but hold together, and leave a very small surface to heal when the desiccated portion separates. The application of stearate of zinc helps to protect the stump until it heals.

The forceps which I use is like the compression forceps but with very narrow blades.

This method of operating is sufficient in the ordinary forms of angioma. When the neoplasm is caused by a chronic inflammation of the urethral glands, the best method is to pass a fine probe up into the canal and cut down upon it with the cautery point from the vaginal surface ; in other

words, lay the ducts of the glands open. This divides the neoplasm on one side, and an incision should be made with the cautery on the opposite side, which divides the neo-



FIG. 69.—Operation upon diseased urethral glands. A fine probe is passed into the gland; the tissue is rendered tense; the knife is about to cut down upon the probe.

plasm into two equal parts; then each part is grasped in the forceps and removed in the way I described in the treatment of angioma. The method of treating the disease of the urethral glands is illustrated by Figs. 69 and 70.

I have succeeded in completely curing the chronic inflammation of the glands by laying their ducts open in this way and removing the neoplasms at their terminal ends, excepting in a few cases where the inflammation still persists in the glands. To correct this I generally do a second operation. I pass the cautery point into the gland and cauterize it sufficiently to destroy it. I have succeeded in

curing all cases in this way, except in tuberculosis of the urethra. That disease has continued when the upper portion of the canal was involved before operating.

The method of operating in cases of narrowing of the meatus urinarius is this: I pass a bivalve speculum into the urethra and put the meatus on the stretch. The band of tissue below or on the vaginal side which extends from one blade to the other is made tense, and is easily divided with the cautery; in fact, it is necessary to be deliberate in making the incision, or else hæmorrhage will follow; not a hæmorrhage which will give any trouble except delay, as it prevents continuing the use of the cautery to complete the operation.

In cases of papillæ within the urethra, caused by hyper-



FIG. 70.—The incision gapes after splitting open the gland.

plasia around the follicles, the treatment with the cautery is difficult, but if properly employed gives the most prompt relief in those cases of chronic inflammation which have been called granular urethritis. After having made a clear

diagnosis and localized the points to be destroyed, I introduce the endoscope with an open end, up as near to the neck of the bladder as can be without permitting a flow of urine; the instrument is then withdrawn until one of the points to be touched comes into the field of vision; the cautery is then passed up, and the point slowly touched once, which is, as a rule, sufficient. The endoscope is then again withdrawn until another diseased portion appears, which is treated in the same way, and so on until the treatment is completed.

#### IRRITABLE ULCER OF THE NECK OF THE BLADDER

The most troublesome of all diseases of the urinary organs, both in the way of causing suffering to the patient and botheration to the surgeon, is this ulcer or fissure at the junction of the urethra and bladder.

The first difficulty is in making a diagnosis. In fact, I have never been able to fully expose a fissure in the location except with the glass endoscope, and I have tried all other instruments in use. The treatment also is difficult. When the fissure is exposed by means of an endoscope open at the distal end there is a continual oozing of urine, which interferes with the use of the cautery. If the fissure is on the vaginal side of the urethra, this is obviated by using a fenestrated endoscope and bringing the fissure into the field of vision, while making pressure against the endoscope from the vagina with the finger, to force the diseased portion of the mucous membrane into the fenestrum and prevent the outflow of urine. I then dry the part with a small piece of bibulous paper, and apply the cautery by simply drawing the point slowly through the ulcer so as to completely destroy its surface.

To a certain extent lateral fissures can be managed in the same way, but when the fissure occurs above, which fortunately seldom happens, it is almost impossible to employ this treatment. Perhaps when I have had more experience I may be able to report quite favorably of this

treatment. Up to the present time it is not completely satisfactory, though the best that has been obtained so far in treating those forms of urethral affections already alluded to.

I find that with the use of cocaine general anæsthesia is not necessary, at least in patients who possess a fair degree of self-control, but I should advise the use of an anæsthetic until the surgeon has acquired some skill and dexterity in the management of the endoscope and the cautery.



## CHAPTER XIII

### ELECTRO-HÆMOSTASIS IN THE TREATMENT OF RECTAL HÆMORRHOIDS

THE clamp and cautery was used for a long time in operating for hæmorrhoids, but the results obtained were not altogether satisfactory. The clamp spread out the tissues so that a broad stump was formed, and after removing the clamp the tissue of the stump separated, leaving a broad surface to heal. Bleeding was often caused by the action of the bowels unless confined for a long time, and healing was retarded.

These unfavorable conditions were avoided to some extent by using a clamp with broad jaws, and after cutting off the hæmorrhoid, applying the cautery to the forceps long enough to desiccate the stump in the way that Keith treated the pedicle of ovarian tumors. This required altogether too much time, and it was so difficult to avoid too much or too little heat that I became discouraged and returned to the ligature until the introduction of the hæmostatic forceps. Since then I have adopted that method, and practice it exclusively.

In the preparatory treatment plenty of time should be taken to get the digestive organs into the best possible condition. If the tongue is coated and the appetite impaired, small doses of mild chloride of mercury should be given, followed by a cathartic. A laxative should be given in the evening before the day preceding the operation, so that the bowels shall move in the morning, and at night

before the operation the rectum should be washed out thoroughly.

The sphincter is slowly stretched with a bivalve speculum to a degree sufficient to temporarily paralyze the muscle, but not to tear its fibers or lacerate the hæmorrhoidal veins if possible. The most prominent hæmorrhoid tumor is caught with a Pean forceps and drawn outward (see Fig. 72, *A*), the hæmorrhoidal clamp is applied to its base, and the electric heat continued until desiccation is complete; this requires from half a minute to a minute, rarely more than half a minute, unless the tissues are very large. A shield forceps with shields of horn, tortoise shell or

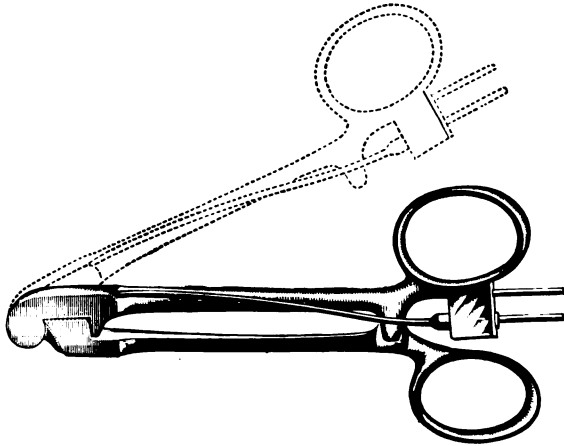

FIG. 71.—Hæmostatic hæmorrhoidal clamp.

ivory, similar to the shield forceps used in ovariotomy, is placed under the clamp to protect the tissues while the heat is being applied.

The clamp (see Fig. 71) is made on the same principle as the ovariotomy clamp described in the chapter on ovariotomy, but is much smaller.

Fig. 72, *B*, shows the clamp in place parallel to the axis of the canal while the current is being used.

Fig. 73 shows the clamp opened just enough to permit the stump to escape from its grasp.

Fig. 72, *C*, shows the stump after treatment; the long

measurement is in the axis of the canal, as it should be, in order that it may rest in the folds of the mucous membrane when the sphincter contracts.

During the process of repair the stump becomes softened by absorption of moisture, and part of it, at least, separates and comes away, but not until the base has completely healed. The reader will observe that a stump exposed on a free surface is not reorganized as is a stump inclosed in the abdominal cavity or in cellular tissue. It appears that the portion of the dried stump joining the liv-

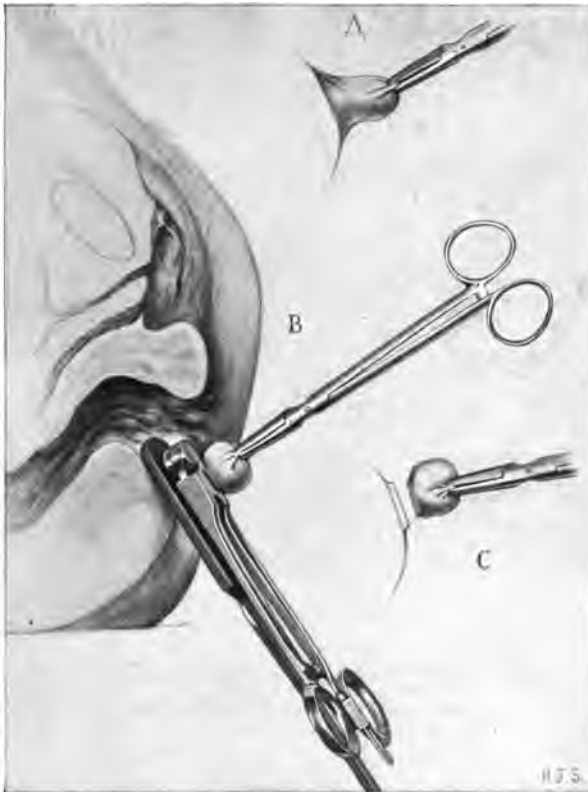

FIG. 72.—A, the hæmorrhoid is drawn outward by a forceps; B, the hæmostatic clamp and shield forceps in position while the current is being used; C, the stump after treatment; the long measurement is in the axis of the canal.

ing tissue may become organized during healing, but the free end separates and is thrown off as stated above. The

mucous membrane remains tender at the site of operation until the process of repair is complete, therefore the parts



FIG. 73.—The clamp has been opened to permit the stump to escape from its grasp.

are easily torn open by distending the sphincter out to any great extreme. On that account the bowels should be kept at rest for several days after operation.

Owing to the stump in its greatest length running parallel to the axis of the rectum, it is in the position most exposed to being opened up when the bowels are evacuated.

Dr. R. L. Dickinson suggested that the danger of opening up the stumps might be guarded against by applying the clamp at right angles to the axis of the rectum, or rather he suggested that it should be made obliquely. (See Fig. 74.) The effect of distending the sphincter would be to draw the edges or sides of the stump more closely together, not to pull them apart. This appeared to me to be a valuable suggestion, and I shall try it, taking care to have the stumps all outside of the grasp of the sphincter when the location of the hæmorrhoid is such that this can be

done. That is to say, I shall form the stump at the junction of the skin and mucous membrane.

*After-treatment.*—The parts are dusted with dry, finely powdered bicarbonate of soda or subgallate of bismuth, applied with the insufflator.

The patient is kept at rest for a week or ten days, and liquid diet given—soups, broths, and gruels being preferable to milk.

As this operation is followed by much less pain than when the ligature is used, opium is seldom required. When

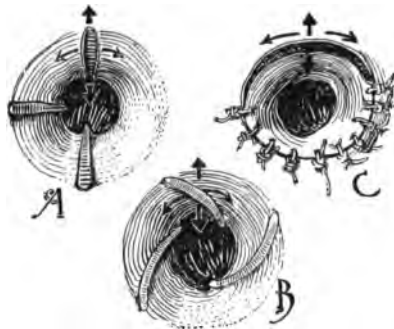

FIG. 74.—Diagrams of scars or stumps after removal of piles, and the strains applied to those lines of union. *A*, ordinary seizure of forceps in removing pile. The tip of the clamp pointing directly in long axis of anus, three bites being sketched, the edges of the mucous membrane of the upper one having pulled apart as rectal plug is withdrawn or fæces pass, leaving a fissure to granulate; *B*, oblique bite here advocated as least likely to be dragged open; *C*, White-head operation partly sutured, circular line of union. The stresses are two—*longitudinal*, in the axis of the anus; and *transverse*, at right angles to that axis. The longitudinal stress, shown by the stumpy arrows, and produced by the shoving onward of the mucous membrane or skin about the anus as a fæcal mass makes exit, can have little hurtful effect on *A*, and much on *C*. The transverse tension, produced by stretching of sphincter by fæcal mass, shown by the longer curved arrows, does no harm to *C*, but great hurt to *A*. The oblique bite, *B*, is least likely to be hurt by the combined strain.—*Brooklyn Medical Journal*, vol. xiii, No. 1, p. 54, January, 1899.

called for, I use liquor opii comp. and tincture of belladonna, instilled into the rectum with a soft catheter or pipette. The bowels can be safely moved on the second or third day, but it is better to keep the patient on spare liquid diet, and wait until the fourth or fifth day. On the evening of the fourth day a small laxative dose of pulve. glycerrhiza comp. is given, and followed in the morning with a dose of phosphate of soda and two hours later an enema of flax-

seed tea. The flaxseed tea is the most agreeable and efficient enema in all rectal diseases when this aid to action is required. After the bowels are evacuated the parts should be thoroughly cleansed by irrigation, then dried with absorbent cotton, and the subgallate of bismuth powder employed. The bowels are permitted to rest for one day, and after that they should be moved each day. Some of the best authorities permit their patients to sit up in about three days, and in about a week they are allowed to go about; but I am sure that this is not the best after-care. It is better to keep the patient quiet until healing is complete, which requires about ten or twelve days. It is claimed that patients treated in the old way are able to be up and at business in a few days, but better results are obtained by taking more time.

Finally, complete recovery takes place in less time than after any other method of operating that I have ever known.

#### FISSURE OR IRRITABLE ULCER AT THE TERMINAL END OF THE RECTUM

To comprehend the treatment of this affection with the galvano-cautery it is necessary to understand its true pathology and causation, especially the latter. Van Buren gives such a graphic description of that disease that I prefer to quote *in toto*: "There is no disease to which humanity is liable—certainly none so insignificant in extent—which is capable of causing more intolerable suffering than the ailment generally known as fissure of the anus. It is more properly styled irritable ulcer of the rectum, for this designation describes accurately the true pathological nature of the disease. The ulcer originates in a fissure or crack in the delicate integument lining the orifice of the anus, or, to speak with greater exactness, in the mucous membrane just about assuming the character of skin which lines that portion of the rectum embraced by the sphincter-ani muscle. Doubtless there are cracks and fissures occurring frequently in this exposed locality, under the influence of costiveness

and violent stretching, which get well promptly without their existence having been suspected; and others again which last a longer or shorter time, and give but little trouble. But in certain conditions of the system, and where, under the necessity imposed by habitual constipation, this forcible distention is repeated daily, the fissure fails to heal promptly; and then, as under all similar circumstances of constantly repeated mechanical irritation, inflammation develops itself in the little wound, and just in proportion as the inflammation advances the effort at repair diminishes, until finally it ceases entirely. The solution of continuity, or ulcer as it is now, being still exposed to constantly recurring mechanical violence and to the contact of chemically irritating substances, is kept thus in an actively inflamed condition and soon puts on all the features of an irritable ulcer."

Van Buren's description is complete, perfect, and acceptable in all respects, except that the causation given is not fully in harmony with the clinical facts as I have observed them. The actual cause of the persistence of certain fissures is that they extend outward from the mucous membrane to the skin, and a small pocket is formed beneath the skin in the terminal end of the fissure. That portion of the skin overlying the lower end of the fissure in the mucous membrane becomes indurated and stands outward so that the pocket remains open and filled with irritable substances, which prevent the parts from healing. Fissures wholly in the mucous membrane and not having this pocket heal promptly.

Fig. 75, *A*, shows a sketch of the anus with the fissure and pocket.

The diagnosis is completed by a physical examination. The books direct that the parts should be separated and a slight inversion produced, which brings the ulcer or part of it into view. It is possible to do this when the sphincter-ani muscle is relaxed, but it is generally contracted, and the patients resist the efforts to bring the lesion into view.

The most satisfactory examination is with the glass endoscope. In fact, that is the only instrument with which anal fissures can be clearly seen. The glass tube distends the parts sufficiently to lay the fissure open and bring it fully into view, and its use causes no suffering on the part of the patient and is far more agreeable to the surgeon than rectal specula or endoscopes in general use.

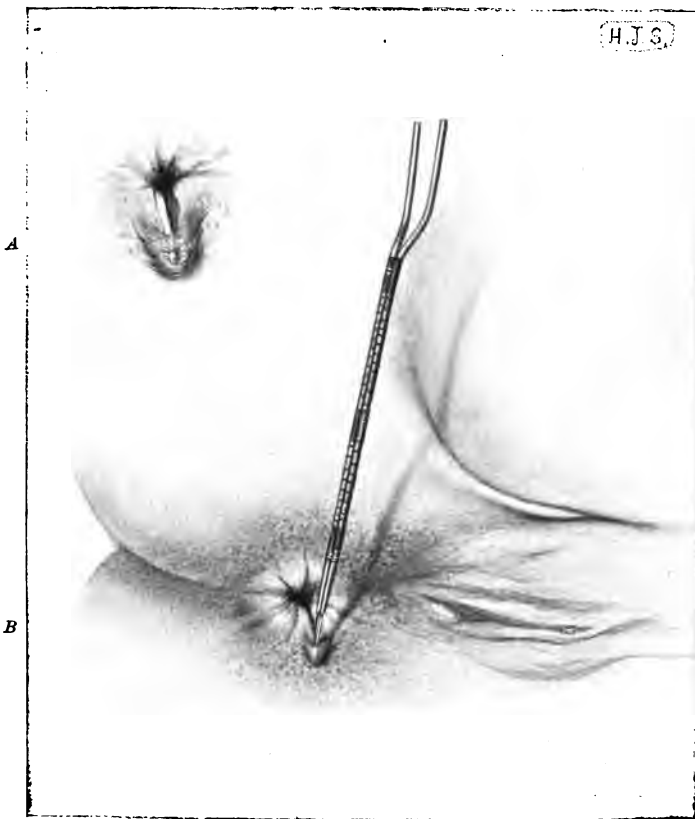

FIG. 75.—*A*, fissura in ano, showing indurated edge and pocket; *B*, treatment with fine cautery point. The pocket is being laid open.

The treatment consists in applying cocaine to the ulcer by means of a pipette, a small Sims speculum is introduced, and then I lay open the pocket at the most dependent part of the fissure with a fine cautery point. (See Fig. 75, *B*.) This exposes the entire ulcerated surface, which is then



cauterized throughout, but only superficially. The cauterization should include the indurated edges of the ulcer, but should not be carried deep into the mucous membrane; only far enough to destroy the diseased tissue. No after-treatment is required. The charred tissue protects the parts below until healing has been completed.

The treatment is not sufficiently painful to require general anæsthesia, and relief from suffering is almost immediate. The ultimate results are quite as satisfactory as the old treatment by stretching the sphincter to divide the fibers of the sphincter beneath the fissure.

The following case recently treated is typical of many that I have relieved in the same way: This patient became constipated after the birth of her third child, and about two months after that confinement began to have all the symptoms of fissure of the anus. Her physician gave her ointments and suppositories of various kinds to use, and treated successfully her constipation, but she obtained no relief from her rectal pain. After three months of suffering her health became impaired and a surgeon was called in consultation who made a diagnosis of fissure, and advised operative treatment. This proposition was accepted by the patient, but her husband was fearful of anæsthetics, so he brought her to my office. The history was fully given, including the fact that she had been treated with local applications, but finding no relief had given up. No mention was made of the proposed operation. A well-developed irritable ulcer was found, and I suggested immediate treatment, and the patient agreeing, I operated there and then. The patient told me that I caused less pain than the examination made by the surgeon who had previously seen her. When I asked her why she had not told me about that, she replied that she wished to find out if I would advise the same treatment or something else that would relieve her without having to take an anæsthetic. Her recovery was perfect.

## CHAPTER XIV

### THE TREATMENT OF NEOPLASMS OF THE SKIN AND MUCOUS MEMBRANES WITH THE ELECTRO-CAUTERY AND ELECTROLYSIS

My attention has been called to this subject especially by seeing three patients who were treated a long time ago, one with electrolysis and two with galvano-cautery. The results were so very satisfactory that they recalled many other cases equally complimentary to this method of treatment. One of the three cases was a nevus situated between the eyebrows of a child five months old. The skin covering the elevation was of a bluish red for about half an inch across, and three quarters of an inch vertically. The tumor disappeared on pressure, showing that the enlarged vessels were mostly in the cellular tissue. It was growing very rapidly. Electrolysis was employed, and that child is now a boy fourteen years old, with no trace of the nevus or the treatment to be seen. The second case was one of epithelioma of the lower lip of a lady. She was examined by a surgeon of reputation, who advised its removal. I fully confirmed the diagnosis by clinical and microscopic examination, and removed the growth with the galvano-cautery. It is now four years since that operation, and there is no deformity of the lip nor any trace of the disease. The third case was nevus pilaris, or hairy papilloma on the cheek. This was removed with the cautery, and there is only a small speck of scar tissue, which is barely visible on close inspection. A hundred or more cases to illustrate the results of this mode of treatment might be given, but these will suffice to bring the subject to the attention of the reader.

Excepting in vascular tumors, in which the large vessels are subcuticular, and in which it is desirable to preserve the skin covering the vascular growth, the galvano-cautery best answers the purpose in all cases. In the exceptional cases electrolysis gives the best results. Skill and accuracy in operating are very essential. The needles should be round-pointed, so that they may close their tracks and prevent bleeding. They should be insulated to within a distance from the point nearly the length of the diameter of the tumor. This enables the operator to bring the acting part of the needle into contact with the tissue to be destroyed, and yet preserve the normal skin at the point of puncture. The electric current used should be strong enough to produce chemical decomposition at the negative and desiccation or cooking, but not charring, at the positive needle. These changes in the tissue are manifested by its becoming hard, especially along the line of the positive needle, which becomes immovable by sticking to the tissue. When these changes have taken place the current should be reversed and continued until the positive needle becomes loose.

If the needles are withdrawn without reversing the current, troublesome hæmorrhage follows and interrupts the treatment. If there is no disposition to bleeding when the needles are partially withdrawn, they should be removed and again introduced into the parts of the tumor remaining unaffected, and the current used as in the first instance. In medium-sized tumors the treatment can be completed by two introductions of the needle, but if any part escapes, as shown by the soft condition due to the circulation continuing in some of the vessels, the procedure should be repeated. The needle punctures on the surface should be closed with collodion to prevent the entrance of anything that might cause suppuration. Usually repair goes on favorably along with the absorption of the destroyed tissue. If suppuration takes place the pus should be washed out through the needle punctures, and drainage kept up with a few horsehairs or some twisted silk.

The galvano-cautery, certainly, so far as results are concerned, is infinitely the best method of removing neoplasms from the skin and mucous membranes, excepting in such cases as just mentioned. When properly employed it causes less pain during the operation, the recovery is much more prompt and complete, and the scar tissue that follows is very much less in extent than by any other method of dealing with these growths. The objections to the various forms of caustics, such as nitric and chromic acid, are that they do not completely destroy the tissue; that they cause very much more pain and suffering; that they are not so certain in their results; and that they leave far more unsightly scars.

That which comes the nearest to the galvano-cautery is the paste of chloride of zinc, lactic acid, and caustic potash. These have been employed by Dr. I. N. Bloom, of Louisville, Ky. Of any results with which I am familiar his approach most nearly those obtained by the galvano-cautery; but they fall short of accomplishing the objects that are obtained so thoroughly and completely by the use of the galvano-cautery. Considerable practice is necessary to acquire facility in technique.

The great object is to thoroughly destroy the diseased or abnormal tissue with the cautery at a degree of about red heat, and, while destroying all that is abnormal, not to go beyond the boundary line or encroach upon the normal tissue. It is very important, especially in vascular growths, to apply the cautery to the tissue to be destroyed before turning on the heat. If it is heated and then applied, there is very great danger of hæmorrhage, especially in vascular tumors. A small cautery point should be used, unless the growth is very large, and it is most convenient to place it into the center of the mass to be destroyed while it is cold. The heat being turned on, the cauterization or destruction of the tissue should proceed from the center toward the circumference, so as to make it complete without going beyond the boundary of abnormal tissue. It is

always well not to go too deep at first. If it is found that there is still some diseased tissue deeper down, the ground can be gone over again until the destruction is complete.

In operating upon small tumors about the mouth, cheeks, or forehead the parts should be held perfectly to prevent twitching of the muscles. Neglect of this may cause the cautery to slip and injure the normal skin and lead to unnecessary scars.

In angioma, nevus, and epithelioma, especially when the mass or growth is large and vascular, it is better to begin at the circumference and work toward the center, always using the cautery at a dull-red heat, since if the heat is too great—that is, white heat—there is sure to be bleeding. In fact, in cases of angioma it is impossible sometimes to operate in this way without having very decided hæmorrhage. In such cases I have adopted another method which answers very well, and that is to seize the mass with a hæmostatic forceps in the central portion or where the vessels are largest, and strongly compress it, then turn on the electric heat, and desiccate it before letting go. This will control the bleeding in the larger vessels, and then with the cautery point the rest of the tissue at the outer margins of the growth can be destroyed in the way already described. That method of operating can also be done in cases of epithelioma, but the results are not quite so satisfactory, because the friable tissue breaks down in the grasp of the hæmostatic forceps and so can not be controlled in that way; but in small vascular growths the results are very satisfactory in operating as described.

This method is equally applicable in case the part operated upon be mucous membrane or skin. Where the diseased part is located on the mucous membrane, say of the cervix uteri, the lip, the tongue, or any portion of the mouth, the pain is slight, and in the most sensitive cases it is only necessary to use a little cocaine to be able to operate without causing any great distress. Indeed, this is the

most painless method of operating, as it causes much less pain than any caustic or paste that I know anything about. In fact, it is not necessary to employ an anæsthetic except in large epitheliomatous growths about the face. The most sensitive patients usually tolerate well the operation anywhere on the skin, unless the growth is unusually large. In case one fails to remove all the diseased tissue, which sometimes happens, it is very easy to make a second application after the healing process has been completed and the eschar has separated and come away, which usually happens at the end of a week.

The condition of the parts when the operation has been well done is simply this: All the tissues are burned away or destroyed, and the surface is covered with a thin layer of charred tissue, which shows as a black mark outlining the extent of the original tumor. A few hours after the treatment the mucous membrane or skin around the cauterized portion becomes quite red, but this redness passes off by the following morning, or sometimes very much sooner; and then all that remains to indicate the field of operation is the spot of charred tissue, which is not by any means unsightly. There is, of course, no dressing necessary. The char forms a perfect crust, under which the tissues heal kindly and very quickly. It is needless to say that the operation is aseptic, and hence there is no way by which any pathogenic germs can be left in the wound to set up inflammation. This probably accounts for the rapid healing, as in about five or six days the charred tissue usually separates, comes away, and leaves a red surface which requires no further care. When the charred tissue separates the surface is usually completely healed, and differs from the surrounding tissue only in being of a deeper color. During the healing process the parts contract, so that on the separation of the charred crust the scar is very much smaller than it was at the close of the operation. The redness fades away gradually, and at the same time the parts keep contracting, so that in the course of time the scar is almost, if not completely,

imperceptible. A scar of a magnitude that is noticeable is left only in case the tumor is very large.

A point of interest in the management of nevi pilares, that are so frequently seen on the face, is that in such cases it is necessary to carry the cauterization deep down, almost through the true skin, so as to destroy the hair bulb completely. If one cauterizes only superficially, the hairs will grow up again and no great benefit will result. The cauterization should be carried down deeply into the center where the hairs are, and then continued upward and outward toward the surface, so that when the entire growth is destroyed the cavity left is cone-shaped, the apex of the cone being deep down in the skin. Cases treated in this way do remarkably well, because this cone-shaped opening contracts nicely and the results are finally very gratifying. I have in mind at this moment a large number of such growths on the face which were so treated. The great point is to obtain complete, perfect results with the most desirable cosmetic effect, and the least possible or no disfigurement from scars.

This method of operating gives vastly better results than any other means at our command. From quite an extensive experience I know that the results obtained are better than those with excision by means of a knife. In operating with a knife it is necessary to make a long incision and unite the parts with sutures, and the result invariably is that the suture marks and a long scar are left. This is the fact even if every precaution is taken, and the best possible results are obtained in the way of immediate union.

In case there is any suppuration, as may happen at any time in spite of the utmost care to obtain aseptic conditions, there will sometimes be a little failure of union, and an ugly scar is left to annoy the patient. When the cautery is used no dressing is necessary, as the cauterized or charred tissue is itself by far the best dressing possible.

Again, if we compare the results with the caustics, such

as nitric or chromic acid, the advantages are markedly apparent in that these invariably leave a very ugly scar that does not disappear completely, and remains a glaring defect for a long time to mar the beauty of the patient. The same may be said with reference to the use of pastes, such as already have been alluded to. They all leave very ugly scars compared with the scar that is left, or the absence of scar, as it might be called, when the cautery is employed. This is one of the most important advantages of this way of operating; and it is not the only one, for the method has advantages in every particular over all other known methods. My attention was first called to the galvano-cautery in the treatment of cancer of the uterus by my friend Dr. John Byrne, and I have always felt grateful to him for his valuable instruction. Dr. George M. Beard taught me how to practice electrolysis in the treatment of vascular nevi, and I desire to pay tribute to the memory of that gifted man who was one of the first to develop scientific electro-therapeutics.



## CHAPTER XV

### ASEPSIS AND ANTISEPSIS IN SURGERY

SUCCESS in surgery depends upon cleanliness as well as skillful and accurate operating, and in estimating one's work the methods of obtaining aseptic conditions by means of antiseptic methods must be taken into account.

Therefore I have deemed it expedient to give a chapter on this subject to show the conditions under which my operative work has been done. Much of detail has been omitted to make room for that which is considered important in the writer's practice.

Surgeons are fairly well united in their opinions regarding the beneficence of the modern discoveries in bacteriology, the germ causation of disease, and the inestimable value of disinfection and sterilization as means of prevention of surgical affections. Harmony prevails also to a gratifying extent regarding the principles of aseptic and antiseptic surgery. Still there is much diversity of opinion regarding the methods of practical cleanliness in all operative work.

There are, indeed, many ways of trying to keep wounds free from septic contamination and keeping them clean during the healing process. In fact, there are nearly as many methods as there are distinguished surgeons. The aim and objects are the same with all, but the means by which the results are obtained differ in detail very greatly. The methods of asepsis in surgery were very complicated at first, and they are still somewhat so. The tendency has been toward simplicity, and in proportion to the discovery of uncomplicated methods efficiency has been attained.

The same light that revealed the part that germs play in the causation of disease, and that made clear the prevention of all kinds of sepsis, led with equal scientific certainty to improvements in sanitary architecture or construction of hospitals and homes for the sick.

In this department of hygiene and preventative medicine the progress toward perfection has been so vast and varied that volumes might be filled with the records. Specialists in sanitary science, aided by skilled engineers, intelligent, honest plumbers—there are such nowadays—make the selection of proper sites for institutions for sick and injured, and by faultless construction fulfill all the requirements in foundations, ventilation, lighting, heating, and draining. The recent improvements in this regard are well-nigh perfect and quite familiar to all who take an interest in the subject. The special efforts now being made relating to sanitary architecture are directed to facilitating disinfection and maintenance of cleanliness. This is more directly related to operative surgery; hence I may with propriety note some of the improvements that have been recently made and especially connected with the subject now under consideration. The first architectural principles in the construction of rooms for the sick are to guard against places for the accumulation of dirt and lodgment of disease germs.

The best work on design and construction of institutions for the care of the sick that I have seen anywhere is that of Marshall L. Emery, an architect who has taken great interest in this branch of his art. Evidently he first informed himself by consultation with medical men regarding the requirements of a hospital and endeavored to meet them. The following is taken from Mr. Emery's writing on the subject:

#### SANITARY HOSPITAL CONSTRUCTION

A modern hospital, designed and arranged to meet modern requirements, is the result of an evolution extending

over many years and embracing the conscientious labors of many able investigators in both the medical and architectural professions.

The progress in the science of medicine and surgery has made from time to time new demands upon the architect and the builder, and while a great many of these demands have been fully met, there are some which require still further study and invention in both the material and the mode of construction. It may be assumed for present purposes that the science of hospital planning is well advanced toward the ideal; the size, shape, and sequence of the various departments have been gradually reduced to a typical or standard arrangement which is capable of being carried out, and a satisfactory result obtained where space and means are available. In the matter of constructive detail, however, the requirements of modern medical science are greater than can be provided by the means and methods of building at present in use. This may be shown by taking for example a single room, and as an operating room is probably the most severe in its demands, it may be taken as a type for all the rest, on the assumption that any detail which meets the conditions in such a room will be satisfactory in any of the others, though the matter of cost would undoubtedly preclude the use of this construction throughout the whole building.

An operating room consists, in common with all other rooms, of the following parts: Walls, floor, ceiling, doors, windows, sash, door- and window-jambs and casings and base. All the matters of detail must conform to the following principles: They must be hard, non-porous, durable, as free from joints of any kind as possible, and free from all sharp corners or angles, or any other feature tending to collect dirt or septic matter, or offer any obstruction to its ready and complete removal; furthermore, they must be of such a nature that they shall not change their size, shape, or positions after erection, but shall remain as originally set up—in short, they must not shrink, warp, or settle, or do

any of the disagreeable things that building material is constantly doing.

In some of the details the principles are easily lived up to, and with some forms of construction and sufficient means many of the demands can be complied with; but even at best, there are some required features which present material and building methods can not provide.

It might, of course, be possible, theoretically, to design a room where all the conditions should be supplied, but such a room would be a practical impossibility, owing principally to its great cost and the difficulty of procuring sufficiently skilled labor in its construction.

The greatest obstacle to be overcome lies in the almost imperative necessity for the use of wood to a greater or less extent, depending upon the money to be expended.

We can best proceed by taking up the details of construction as already enumerated, beginning with the walls. One or more of these will, of course, be an exterior wall containing one or more windows. As the ordinary form of construction suffices and is generally familiar, we shall discuss but one feature, namely, that of insulation. All outside walls have to be built to prevent condensation of the warm air of the room, and to prevent loss of heat by conduction through the material of the wall. This is generally accomplished in one of three ways—building the wall so as to leave a hollow space in the wall itself of from two to four inches; building in the wall a course of hollow bricks extending from bottom to top; or lining the wall on the inside with hollow terra-cotta tile. In cheap construction wood furring strips are used to which the lathing is nailed, an air space being formed thereby about equal to the thickness of the furring strips, usually from one to two inches. Either of the first three methods is good, and possibly the first the best, if properly built; though the terra-cotta tiles are most frequently used.

The partition or interior walls may be of three forms: Solid brick, rough, pressed, or enameled; hollow brick, terra-

cotta tiles, or solid plaster cement; or a light framework, for high ceilings, long spans, etc. The solid brickwork is the best; but for small walls, or where walls are carried by the floor construction or girders, it is generally more advantageous to use one of the latter forms. The hollow tile range from two inches to eight inches in thickness, and average about sixteen inch squares. They are laid in mortar in very much the same manner as common brick. The solid plaster partitions have come into use within this last five years, and have many advantages. They cost less than solid brick or terra-cotta, and as they are but two to two and a half inches thick they save considerable floor space. They are lighter than brick partitions and do not require any specially heavy floor construction, but can be placed where desirable without reference to beams and girders.

The floor construction is important, as the ceilings and other matters depend largely on their stability.

If the money at disposal will allow, steel beams should of course be used; and if not, then Georgia pine beams of large section and as free from sap as possible.

In the case of steel beams, the spaces between beams may be spanned in various ways—either by several forms of hollow-tile arches, or by a number of patented systems consisting of a combination of iron bars or netting and concrete. There is little choice among the several forms for hospital use. Where the loads on the floors are comparatively light, the cost is generally in favor of concrete and iron. If wood beams are used, there should always be double floors laid, with layers of water- and fire-proof material between them, unless a tile or other non-combustible flooring be used. Tile, concrete, or mosaic floors are sometimes laid on wood beams, but the result is bound to be unsatisfactory, and the practice is to be avoided as far as possible. Should it be necessary, however, it is accomplished by nailing cleats to the sides of the beams two to three inches below their tops, to which a rough floor is nailed. On this rough floor is laid a bed of concrete to within about an inch of the

finished floor; this inch being left for the tile, marble, or cement finishing surface. As ceilings are almost invariably finished in plaster, it is only necessary in the ceiling construction to provide a sufficiently strong and rigid foundation to support the plaster. If steel beams be used, a system of light iron framework is secured to the lower edges or "flanges" of the beams, upon which wire or sheet-metal lath is stretched and plastered.

In the use of wood beams the wire or metal lath is nailed directly to the beams, or to wood furring strips nailed to them.

The floors may be finished in either tile, marble, mosaic, concrete, or wood block. The first three forms are all familiar, and of these the tile is preferable, provided a hard "vitrified" tile be used not exceeding two inches square, larger tiles being apt to loosen. Hardwood blocks, about two inches wide and twelve inches long, put down on a concrete foundation with asphaltic cement, have been used lately to some extent, but as they cost nearly as much as tile or mosaic, and have to be kept constantly "filled," waxed, or varnished there seems to be little if any advantage in their use.

If necessary to use an ordinary wood floor, it should be laid double, as already mentioned; the upper flooring not exceeding two inches in width, and of hard, close-grained wood, thoroughly seasoned, dry, and well nailed. The rough or under floor should be laid diagonally across the floor beams and the top or finished floor laid at right angles to them. The top floor should be smoothed off and planed over the whole surface, and "filled" and finished immediately after.

Wood floors are often laid on a fireproof construction by bedding wood sleepers two inches thick on the steel beams and anchoring them there by leveling up to the top of the sleepers with concrete, and then laying a double floor, as just described.

The obvious objections to wood as a flooring material will, of course, apply to all wood floors, and they should

never be used except where necessitated by lack of means. A cement floor will cost but little more than a good wood floor, and is certainly far better in sanitation, permanence and ultimate economy.

The best material for wall and ceiling finish is "Keen's" cement, the best brands being imported from England, where it is more largely used in hospital construction than here. When properly applied it presents a very dense, hard surface, and, skillfully worked, is capable of great smoothness and polish. Incidentally it may be mentioned that it is the basis of artificial marbles. The cost of this material is a great drawback, and in ordinary work its use is limited to wainscots, bases, window sills, and similar exposed places. For the upper part of the walls and for ceilings patent plaster or "dry mortar" answers very well, though, while not so dense or hard as the "Keen's" cement, it is a great improvement over common lime mortar. "Patent plaster" is merely a basis of plaster of Paris mixed with sand and a retarding agent, kept secret by the makers, which slows the setting of the plaster of Paris sufficiently to allow the walls to be properly worked. The mixing and proportioning of patent plasters is done by machinery, and is consequently done in a more thorough manner than if done by the hand of an indifferent laborer, which is one reason for its superiority over common plastering mortar.

The angles formed by the walls, and the walls and ceilings, should be "rounded" or finished with a cove, instead of forming a sharp corner. This cove should not be too large, as it will be liable to crack if formed with a large radius. A radius of two inches will be found sufficient for all purposes, and is easily made.

The forming of the curve in wall and ceiling angles, while simple, requires a considerable degree of care and skill on the part of the plasterer to make it straight and true, and to make all miters and intersections meet and join properly.

The angle between the floor and wall should be coved



in the same manner, and where a tile, mosaic, or cement floor is used there is no trouble; where a wood floor is used, however, it is impossible to make a joint or connection between the wood and plaster which will not open, even if it be made tight when first put down. This is another strong objection to the wood floor.

If tile be used for a wainscot or wall finish the coved corners are formed in the tile themselves, and, if necessary, special tile may be designed to suit different conditions or positions.

The demands of hospital design present little that can not be provided in construction as far as walls, floors, and ceilings are concerned. With doors and windows the case is different, and it is here especially that future study and invention are to be employed.

The difficulties presented may be best appreciated by referring to drawings. Fig. 76 shows a window frame and sash in ordinary work, and in fact even in some hospital work. A glance will show how unfit it is for any use where it is essential to obtain thorough cleanliness; the corners and angles offer abundant opportunity for the collection of dust, which will increase as the wood shrinks and joints open.

Fig. 77 shows a window designed to offer as far as possible the least chance for the lodgment of dirt and least obstruction to its removal, but even this construction leaves much to be desired. The angle, *A*, between the casing and jamb has to be covered with a molding, because it is impossible to make the wood and plaster join together closely enough to avoid a ragged joint, and even with this molding there will be an open joint somewhere unless the workmanship is far above the average; and the sash itself offers a sharp angle between the glass and wood, which it is as yet impossible to avoid.

The stop bead against the stile offers another joint, *B*, which is sure to open through the effect of atmospheric changes; still, the improvement of one over the other is



quite encouraging, and the time will undoubtedly come when many present objections will be overcome.

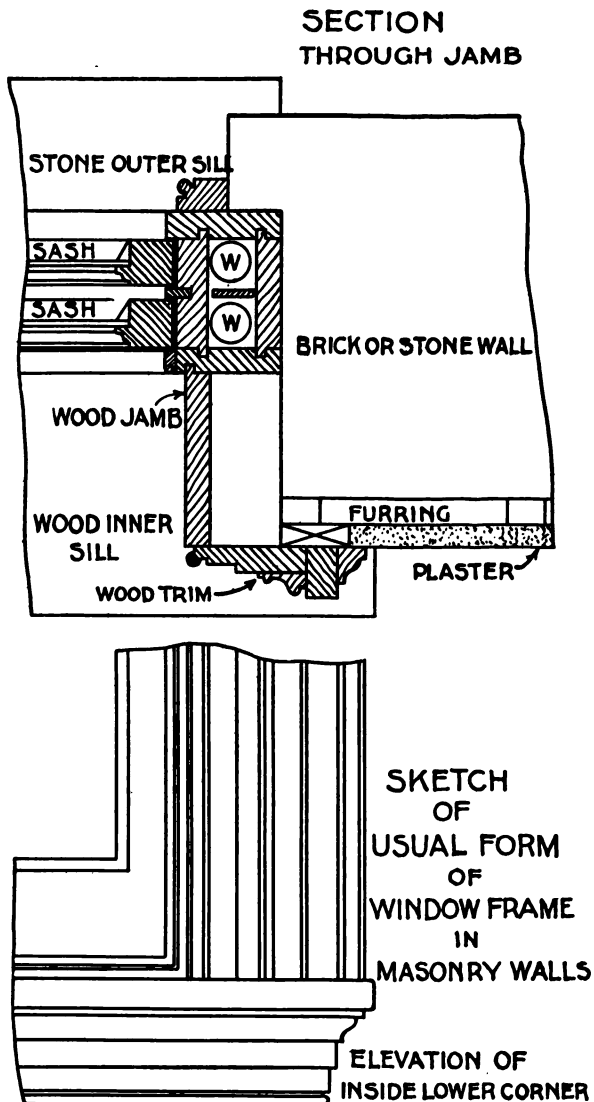

Fig. 76.

What is true of the windows is equally true of the doors. Fig. 78 shows a door in an ordinary twelve-inch

partition finished in the usual way, and Fig. 79 shows the best that can be done at present in the way of elimination of the corners, joints, etc., which remain and are objection-

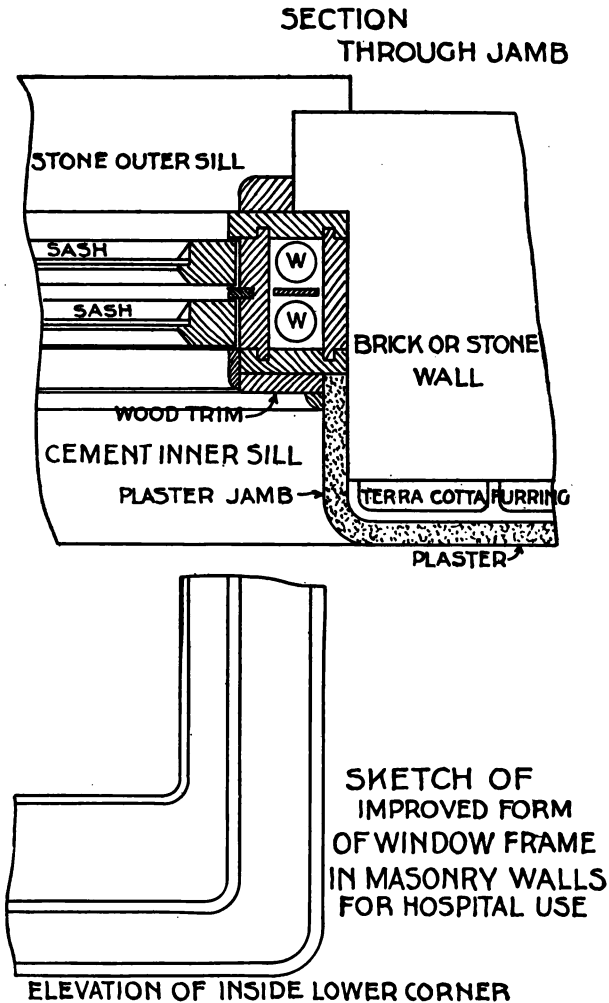

FIG. 77.

able, but at present unavoidable. Where the partition of wall is less than five or six inches thick it is necessary to have a casing on one side, and in a two- or three-inch wall a casing on both sides is necessary. (See Fig. 80.)

Where a casing is used, the cove at the floor is interrupted, and more corners formed. The wood casing is usually received by a marble base block, which prevents

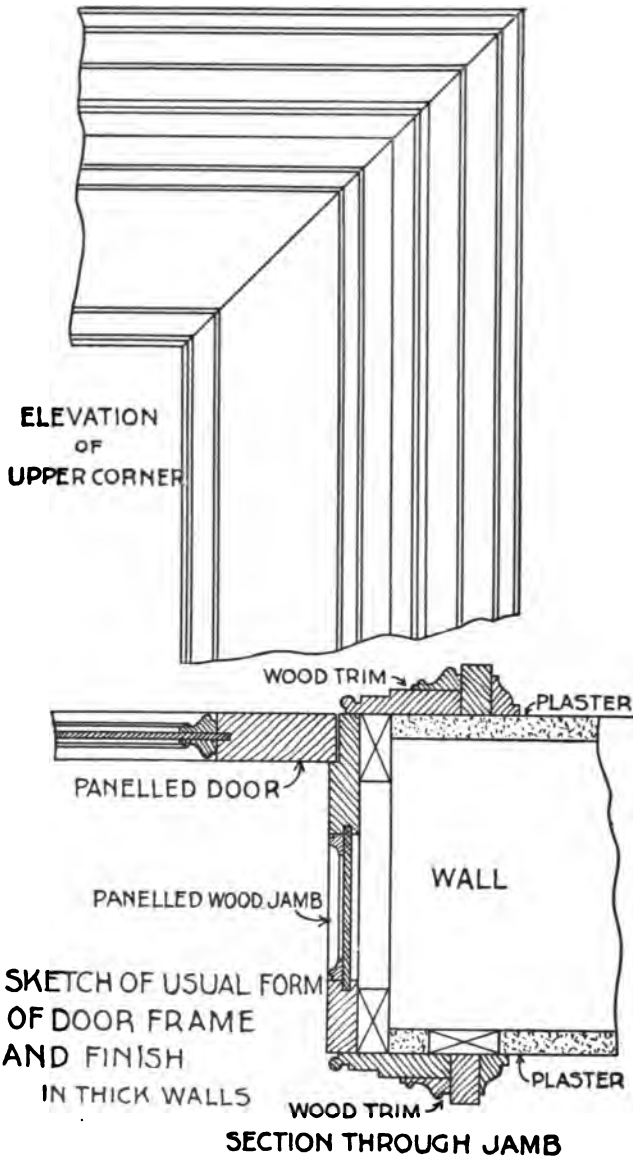

FIG. 78.

the casing reaching to the floor, where it is liable to injury by frequent wetting in washing.

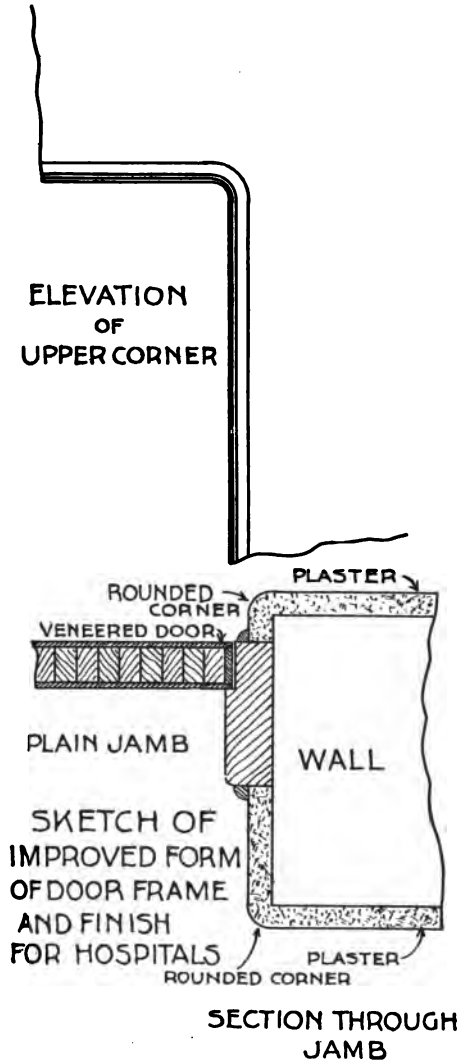

FIG. 79.

Where the casing is omitted, the cove at the floor returns around the wall jamb, or finishes against the wood door jamb.

With reference to the doors themselves, the usual pan-

eled door is obviously objectionable, on account of the numerous sharp corners and angles.

The best substitute for practical use is a "solid ve-

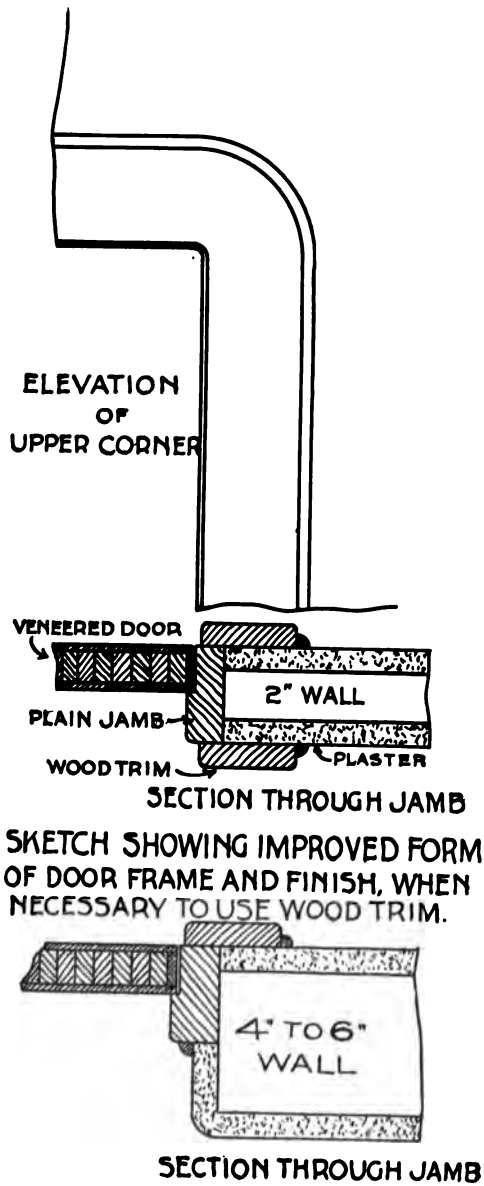

FIG. 80.

neered" door; that is, a door formed of a glued-up pine core, and veneered on sides and edges with a hardwood veneer, forming a perfectly plain surface, which may be kept filled and polished.

Marble doors have been used to a very limited extent, but they are heavy and expensive, hard to move, and unless the hinges or pivots are very hard, and carefully made and adjusted, they are liable to wear down and sag. The marble, however, is porous, easily stained, and altogether the most objectionable of all. Bronze doors would answer best, but they are too expensive for hospitals as a general rule.

#### HOSPITAL PLUMBING

In the matter of plumbing, improvements in material and fixtures have reduced in a great degree many of the difficulties formerly encountered in the proper equipment of hospitals. Fixtures for almost all purposes are now made of heavy glazed earthenware, in designs or forms needing no encasing or surrounding material. A porcelain bath tub is a typical example; when set it is complete, no wood curbing or boxing being required, as in the case of the older copper-lined tub.

The price of these earthenware goods is practically within the reach of an institution with but limited means; for instance, they are now being used in a certain small village hospital, costing less than eight thousand dollars.

In some ways, however, the "improvements" in modern plumbing fixtures are of doubtful character, such as a wash basin with supply and waste cocks operated by treadles on the floor. In a general way the questionable value of these improvements lies in their complexity, rendering them difficult to keep clean or to keep in order. The number of valve mechanisms, traps, wastes, etc., is almost without end, while the really desirable patterns are very few.

In short, the simplest form of any fixture with its accessories is always the best, provided the construction is satisfactory. A plain "S" trap with vent connection seems at

the present stage of progress to be the best to be had, and a "standing" waste and overflow the most satisfactory for general use. By a "standing" waste and overflow is meant a simple tube whose lower end fills the outlet of bowl, sink, or tub, and whose upper end is open, the tube standing vertically, and its height determining the depth of water in the fixture. Such a waste is the simplest possible thing to keep clean, and, being wholly exposed, is always open for complete inspection.

The trap should in all cases be placed as near the outlet of the fixture as it is possible to get it, and the waste from fixture to trap should be perfectly straight. The strainer in the outlet of the fixture should be removable so that the waste can be thoroughly cleaned.

The bad air in many bath and toilet rooms is due to the fouling of the inaccessible waste and overflow connections from fixture outlets to traps, and these same connections may easily form favorable germinating places for dangerous bacilli.

The whole aim in the plumbing of a hospital, as well as any building, should be the greatest possible simplicity. The number of fixtures should be cut down to the lowest possible minimum, they should be grouped together as nearly as possible to a few vertical lines, and the fixtures themselves should be of the best material and plainest design and construction consistent with specific requirements.

The arrangement of fixtures in the various rooms should be such as to permit all piping to and from them to be run in the most direct manner and so as to make the distance from main lines of supply and waste as short and as straight as possible. All waste pipes should have a pitch of not less than one quarter of an inch to a foot. All bends should be of large radius and clean-outs placed at frequent and readily accessible points. All connections, at least in the rooms containing the fixtures, should be made with screw joints, so as to be easily taken down and put up.

Where the means at hand will permit, the main lines of waste, soil, and vent pipes should be of galvanized wrought iron screwed together, rather than the usual form of cast iron with lead calked joints which can not be depended upon to remain tight.

The principle of placing all bathrooms, water-closets, etc., in a pavilion separate from the hospital wards is good. In such an arrangement the pavilion is reached by short, connecting corridors having openings on both sides so that a cross current of fresh air is always maintained between the main building and the pavilion containing the plumbing. This separation, of course, requires space and money, and may not always be had; some modifications costing less may, however, be within reach, and the nearer the approach to the ideal the more satisfactory will be the result.

Whether the plumbing fixtures are contained in a separate pavilion or inclosed in the main building, the main vertical lines of piping should be placed in a specially arranged vertical shaft extending from the house drain at bottom up to and above the roof. This shaft should be large enough to permit of the proper spacing and arrangement of all pipes, and for a man to conveniently reach all connections and branches to fixtures. The branches to fixtures should be run in this shaft so that there would be only the supply cocks and trap visible in the room. If impossible to reach a fixture by a branch in the shaft, then only so much as is necessary should be run on the ceiling of the room below so as to avoid horizontal pipes at or near the floor, as these present almost insurmountable obstacles to thorough cleaning.

The vertical shaft containing the main pipes should have open iron gratings at floor levels instead of solid floors, and should have no openings into it except a small "manhole" or door at the bottom, the various floor levels being reached by an iron ladder built in the shaft itself. To complete the scheme the shaft should be heated so as to produce a strong upward draught in the soil, waste, and vent pipes and their



branches, so as to quickly and thoroughly oxidize any organic matter adhering to their sides.

Floor drains should be avoided as far as possible, and where necessary should discharge into a water-supplied sink placed in a shaft as already described or in a room below. The sink being connected to the waste pipe in the same manner as other fixtures, the outlet in the floor should have a cover which could not be closed until a cap had been screwed down over the waste, thus insuring complete isolation of the floor drain from the main drains and wastes.

The sink or basin in an operating room should discharge in the same manner as the floor drains, so as to have no direct connection with the drainage system.

Polished brass or nickel-plated piping requires too much time in cleaning for general use; unpolished brass pipe and fittings, painted with enamel paint, will be found more serviceable where economy of labor is to be considered.

Much attention and care is necessary to make water-tight connections where pipes pass through tile or similar flooring, especially hot-water pipes, so that the floors may be thoroughly washed without leaking.

#### HEATING AND VENTILATION OF HOSPITALS

Possibly no part of hospital construction has received more attention than the heating and ventilating. The amount of fresh air required for each patient and its temperature have both been satisfactorily determined; the practical operation of supplying the air, warming it, and causing it to circulate completely throughout the whole of each room is beset with many difficulties. For ordinary work it has been found more desirable to divide the problem into two distinct parts, one the heating and the other the ventilating. In this method the air is heated, by large heating stacks located in the lower part of the building, to the temperature desired for the room, say 70° F., the air being at this comparatively low temperature can not counteract the cooling effect of doors and windows and walls; to do this

direct radiators are placed at proper points in the rooms to be heated. This system works well, but the direct radiators in the rooms rapidly collect dust and are very difficult to clean. A more satisfactory but a more expensive method consists in heating the whole volume of air, at a central point or station, to nearly the temperature required by the various rooms, the air passing along main ducts or conduits to the vertical flues leading to the rooms. At the base of each vertical flue is placed a separate and independent stack or indirect radiator, which further heats the air to the temperature required. In this method, every room governing its own temperature, the air may be sufficiently warmed to overcome the cooling effect of outside walls, doors, and windows. This method would probably be as near an ideal scheme as possible to provide.

The matter of automatic control of heating surfaces, such as stacks and radiators, has been brought very near perfection by various forms of thermostatic valves operated by the temperature of the rooms they control. These valves have been found to act with great certainty, so that the temperature may be maintained within a variation of a degree above or below the required temperature. The thermostatic valves are applicable to both systems described above, and as it eliminates the necessity of depending upon attendants to operate hand valves, the temperature is more uniformly maintained.

In the best work the air is filtered through screens of gauze before entering the heating chambers. These screens take out nearly all the dust, so that the air in the flues and ducts is practically clean. A further application of the screen system to special rooms, such as operating rooms, would be of great advantage.

It has been found that by passing the air through screens formed of sterilized cotton batting it is not only cleaned of dust but is also sterilized, and the advantages of sterilized air in an operating room is of course obvious. This sterilizing is readily accomplished by arranging a set of cotton-

batting screens in the flue leading to the room where sterilized air is required, the screens being made somewhat upon the principle of a photographer's "plate-holder," allowing the frame to be withdrawn for the purpose of changing the cotton from time to time, the frame sliding in and out of a trunk or other device built in the flue in very much the same manner as a plate-holder is put into a camera.

The increased resistance offered by the cotton would of course require a stronger draught or pressure of air in the flue, but there is nothing in the scheme which would make it impracticable.

Direct-indirect radiation should never be used where an indirect system can possibly be afforded.

The direct-indirect scheme, as is well known, consists of a radiator with a "box base," into which air is admitted through an opening in the wall directly behind it, the air entering the base of the radiator passes over it, and, becoming heated, enters the room. It is impossible to properly filter the air with this method, and it is also impossible to properly regulate the temperature or supply. As a matter of economy it may answer for some small unimportant rooms in case an outlet flue is provided leading to a main exhaust stack or duct.

Storerooms, clothesroom, and closets should not be overlooked, but should have as thorough ventilation as any other rooms. This is often neglected.

Lavatories and rooms containing water-closets and urinals should be ventilated through the fixtures—that is, the air should be drawn out of the room through the bowls of the fixtures themselves and conveyed by separate flues to the top of the building. In this way all odor may be entirely eliminated from these rooms.

No building can be thoroughly ventilated without the use of a mechanical system, including the use of fans or blowers. Generally, it will be found best to provide two sets of fans, one to force air into the rooms and the other to draw it out.

All rooms should be under a slight pressure, so that the warm air of the room will be escaping through the cracks and openings around doors and windows instead of the cold air outside leaking in and causing draughts.

Double sash or double glazing will be found of great service in making the temperature of a room more uniform, as well as reducing the consumption of fuel. It will also have the effect of reducing the cost of the whole plant, as the glass in windows is by far the most effective medium in cooling the air, and is a very important factor in determining and proportioning the heating surfaces and other parts of the heating system.

The system of exhaust flues and ducts is quite as important as the supply, and should be as carefully developed.

The location of registers in the rooms is also a very important item in securing a complete circulation of air in all parts of the room. Experience has demonstrated that they should both be placed on the same side of a room and near together, the supply being about eight feet above the floor and the exhaust at or near the floor level.

In furnishing hospital rooms and wards the same rules should be followed as in the construction of the building. The furniture should be such as will not lodge dirt or absorb the germs of disease. Simplicity in design and construction guards against the accumulation of dust and dirt, and the material used should be impenetrable as far as possible. Metal bedsteads and washstands are the best in use at the present time when well plated. When these expensive articles can not be afforded, white enamel iron answers as well. Bureaus and cabinets should not be used as a rule; but if permitted, to please lady patients, they should be severely plain, and enameled within and without. Such furniture is easily kept clean all the time, and can be sterilized when the room is treated by disinfection in the way to be hereafter described.

## CHAPTER XVI

### ASEPSIS AND ANTISEPSIS (CONTINUED)

ACCORDING to my observations most of the imperfections in carrying out aseptic methods in surgery occur in admission of patients and the management of their clothing. To guard against all possible infection from without the hospital requires a thorough disinfection of everything which comes into the building. Patients do not always know that they have been exposed to contagious disease; sometimes they will not admit the exposure if they do know of it. One may not disregard this possible danger of patients bringing from infected parts of the city sepsis and infectious diseases. The only safe course is to insist upon the sterilization of every new patient immediately upon her arrival and the disinfection of all her clothing.

The method which I practice is as follows: The patient is at once taken to the dressing room adjoining the bathroom, where her clothing is removed and put into a clean bag and sent to the sterilizer. She leaves her street costume here and is conducted to the bathroom to receive an ammonia bath, and then dressed in a full change of clothing, which had been sent to the hospital the previous day and sterilized. All her clothing and everything which she has brought with her is sterilized by formaldehyde before being taken to her room. By this means the surgeon will assure himself that his new patient has at least rightly begun her hospital life.

*The Preparation of a Patient for all Major Operations.*—The previous night she receives a full ammonia bath, in giving which the nurse is careful to clean all folds of the

skin. It is to be kept in mind that the nurse in charge of the bath must herself be clean. Thorough scrubbing should be practiced and then the body rinsed off with boiled water. The head should be shampooed with alcohol and quickly dried. This having been accomplished, the patient is dressed in sterilized under and night clothes and then put into the bed newly made up with sterilized bedding and bedclothes. A further cleansing is now given the whole abdomen in cases of abdominal section; it is thoroughly scrubbed with soap and water, then washed off with a one-in-two-thousand bichloride solution; finally, a bichloride compress (one in one thousand) and a clean binder are put on. The next morning this last cleansing process is repeated and a new compress and binder are applied. Now that the patient is clean, the utmost care must be exercised to protect her against contamination. She must be conveyed to the anæsthetizing room in a clean carriage or stretcher by clean attendants. The anæsthetist and the attending nurses are dressed in clean garments. The anæsthetizing instruments have been cleaned the same as the instruments for the operation. If the narcosis is not given while the patient remains in her carriage, the couch or table on which she is placed is to be covered with sterilized material. As soon as the patient does not recognize her surroundings she is finally prepared for the operation by scrubbing the abdomen with soap and water, the hypogastrium is then shaved with a sterilized razor, dried and bathed first in alcohol, then ether, and finally bichloride solution, one in one thousand. The umbilicus is covered with collodion, in case it is not to be incised; a clean compress and a new binder complete all and the patient is ready to be taken into the operation.

The room used for operations is twice cleaned, once just after the preceding operation and again in preparation for the next one. Everything which is needed for the operation, except instruments, is brought in; then the formaldehyde is introduced, and the room sealed for five hours.

Blunt instruments are sterilized by exposure in live steam for fifteen minutes; edged instruments are immersed in alcohol (ninety-five per cent) for ten minutes. Of late instruments are sterilized in formaldehyde; and I believe it will prove to be the best method. When needed they are placed into the trays and covered with hot carbolized solution. Formula: Carbolic acid, three per cent; glycerin, twenty-two per cent; water, seventy-five per cent. Natural sponges are washed for twenty-four hours in Javell water, the grit is taken out, and then they are washed in sterilized water; they are preserved in five-per-cent carbolic solution. A careful rinsing in running sterilized water prepares them for immediate use. They should not be used a second time in abdominal work. Gauze sponges, the towels, binders, and gowns are cleansed by the ordinary steam apparatus. The primary gauze dressing is prepared in quantities by saturating it in a solution of carbolic acid, one part to glycerin eight parts. It is always ready, and requires but to have the excess of the solution rung out of it with a sterilized towel immediately before using.

The suture material used is the ordinary braided silk, which is sterilized perfectly by boiling in salicylated wax for twenty hours, in five-hour fractions, with an hour interval. Suture material prepared in this way is perfectly sterile and can be kept so for any length of time. More than that, it will remain sterile in the tissues as long as silver wire. This was demonstrated by both laboratory and clinical experiments many years ago.

Cleansing and sterilizing the hands has always been one of the subjects which claim the most careful attention of surgeons. Even at the present time all methods, and they are many, are questioned regarding their efficiency or practical application. Without discussing the subject I shall give the methods employed in my own practice and which have given the best results in regard to both the patient and the operator.

The method employed is as follows: Soft green ster-



ile soap is used with a sterile brush and running water that has been sterilized by boiling or distillation. The soap is thoroughly applied with the brush, then washed off in the stream of water. This process is repeated four or five times, according to the condition of the hands. The water is made to play with force upon all parts of the hands and arms until all particles of the soap and dirt are washed off. Finally, the hands are placed in a solution of carbolic acid three per cent, glycerin twenty-two per cent, and water seventy-five per cent, and scrubbed or rubbed in with a brush. The excess of the solution is wiped off with a clean towel, and they are ready for use. This is sufficient treatment of the hands, unless the surgeon has been contaminated by examining or operating upon septic cases; then a more careful disinfection is necessary. In such conditions of the hands more prolonged washing is employed, and then they are thoroughly anointed with carbolic acid pure one part and glycerin seven or eight parts. This is applied to the hands and arms and rubbed in with a soft, clean brush and allowed to remain about five minutes. It is then rapidly washed off with a strong stream of rapid-running water. The reason for doing this quickly is that the added water develops the caustic properties of the carbolic acid so that it will injure the skin if permitted to remain in contact with it.

The advantages which this glycerin and carbolic-acid solution has is that the glycerin neutralizes the caustic properties of the acid and does not diminish its power as a germicide. Furthermore, it keeps the hands in good condition. I am quite confident that this is a most satisfactory way of treating the hands so far as sterilizing them, not on the surface only but deep into the cuticle as far as germs go. The mercuric solutions which I formerly used hardened the skin and left living organisms beneath the crust of sterilized tissue. This hardened epithelium became softened in abdominal work and set free the living germs that escaped the sterilizing. That is one of the imperfec-



tions of the usual way of cleaning the hands, which has been pointed out, and has driven some surgeons to the use of gloves while operating.

I prefer to wear gloves when examining doubtful cases, dressing wounds, or handling pathological specimens, and so keep the hands free from infecting germs that can not be destroyed by the method of cleansing which I practice, or any other method known to me.

There is but one objection to the carbolic and glycerin solution, and that is the expense, but that is hardly worth naming in view of the advantages given by its use.

The subject of room disinfection, which has been far from satisfactory in the past, has been greatly improved of late. Indeed, I feel sure that the recent improvements in this direction meet the requirements.

The recent work of Ezra H. Wilson, M. D., is the most perfect that is known to me; and I give here, by permission, his essay on this subject:

The requirements to be met in a proper disinfection of an apartment in which there has been infectious diseases are:

First. Absolute disinfection; by that is meant the destruction of all infectious material.

Second. Ease and rapidity in application.

Third. Economy.

Fourth. The least possible damage to disinfected goods.

The best disinfectant applicable to infected goods such as wearing apparel, bedding, etc., is heat in the form of steam, and it is safe to say that up to the present time no substitute has been found which will disinfect so thoroughly, rapidly, and economically as steam. The objections to its universal application are, that it can not be applied in the disinfection of apartments (walls, floors, ceilings, etc.), and that certain cheap grades of colored goods are often injured by it. The disinfection of apartments by the mechanical process of rubbing and scrubbing with disinfecting solutions, while very thorough, is tedious, expensive, and often damaging to painted and frescoed walls and ceilings.

If, therefore, an agent can be found which can be used for the disinfection of apartments which will be an efficient

germicide and not cause any damage, it is very desirable to investigate it. Such an agent we believe we have in formaldehyde gas, used in a proper manner and in proper amounts. The original method was to produce the gas by the oxidation of methyl alcohol in the presence of incandescent platinum or platinized asbestos, and that is the method now used in the many lamps now in the market, and for which extravagant claims are made. There are many objections to these lamps. In the first place, and what is most important, they do not produce enough of the gas to be of any value. Second, they involve the use of an inflammable and explosive compound, the methyl alcohol, in proximity to an open flame. Third, they have to be lighted and shut up in a room where they are hidden from observation. Fourth, it is impossible in practice to regulate the lamp so as to get the maximum amount of gas, and so to allow of the escape of unoxidized methyl alcohol vapor.

Roux, Baudet, Trillat, and others devised a method of evolving formaldehyde gas from formalin. Formalin or formol is a saturated (forty per cent) solution of the gas in water. If a quantity of formalin is mixed with an equal quantity of a five- to ten-per-cent solution of calcium chloride, it will be found that the boiling point of the mixture is considerably above 100° F. (103° to 106°), and the most favorable temperature for evolving formaldehyde gas is between 95° and 100° F. Thus nearly all the gas is evolved before the mixture is giving off steam. Moreover, it prevents the polymerization of the gas into trioxymethelene.

I will now describe an apparatus for carrying out this process.

#### PARTIAL DESCRIPTION OF AND DIRECTIONS FOR THE USE OF THE TRILLAT AUTOCLAVE

*The Apparatus is packed in Two Cases.*

*Autoclave Case.*—Containing autoclave with gauge; thermometer; two handles and a tin case containing two outlet tubes and a wire to clean same.

*Case of Accessories.*—Special lamp and small can containing alcohol to light same; copper can for the formochloral; tin can for kerosene; cotton wadding for stuffing cracks in windows, doors, etc.; pair of spectacles to protect eyes.

*Trillat Autoclave.*—The vessel of the apparatus is made of heavy copper which is silver-lined and has a capacity of about one and one half gallons. The remainder of the apparatus is mostly brass, highly polished and carefully finished.

The cover of the autoclave, which rests on a rubber band so that it can be tightened to avoid any leakage, is equipped with a pressure gauge, a sleeve in which the thermometer is placed and a stopcock by which one regulates the escape of formaldehyde gas.

*Lamp.*—The apparatus is heated by means of a special lamp, the flame of which is fed by kerosene vapors. By a small screw one can regulate the heat, and by using the pump occasionally one can increase the heat.

*Formochloral* is a saturated solution of formic aldehyde and a neutral or indifferent mineral salt and absolutely free from methyl alcohol. When heated under pressure, formaldehyde vapors are evolved in a non-polymerized condition.

Before putting the formochloral into the autoclave, it should be well mixed so as to distribute any precipitate which may be in the same. This deposit is not an impurity, but on the contrary is one of the essential parts of the solution.

*Directions.*—All cracks around windows, doors, fireplaces, etc., should be stuffed to reduce the possibility of the gas escaping as far as possible.

The formochloral is put into the autoclave, which should never be more than three quarters full, about one gallon or ten pounds by weight maximum. The minimum should not be less than a quart, or about two and one half pounds by weight on account of the possibility of injuring the autoclave. One calculates that one pound of formochloral is sufficient for 2,500 to 5,000 cubic feet of air space.

When tightening the cover, one should screw the opposite bolts little by little so as not to press on one side of the rubber band.

The apparatus after being closed is placed in front of the door of the room that is to be disinfected at a convenient height so that the stopcock is level with the keyhole.

Carefully examine the outlet tube through which the formaldehyde gas is allowed to escape and see that it is free from any obstructions. Then put it through the key-

hole, allowing it to project inside of the room from about four to six inches; then attach it to the autoclave by means of the screw bolt attached to the same. Put the thermometer in place, close the stopcock, and light the lamp.

When the gauge indicates a pressure of a little over or about three atmospheres, carefully open the stopcock little by little, otherwise, should it be opened too rapidly, the liquid in the autoclave is apt to force itself out through the tube and is liable to produce disagreeable results, and for this reason it is well to take the precaution of removing the furniture and to cover carpets that may be directly in the vicinity of where the outlet tube projects.

One knows that the gas flow is well regulated by the very gradual falling of the pressure as indicated by the gauge. The pressure should be kept as near as possible between two and three atmospheres. The vaporization can be considered finished in about one and one half hours when two and one half pounds of formochloral is used; for the maximum charge, ten pounds, two hours suffices ordinarily, and one must always stop the operation when the thermometer is over  $135^{\circ}$  and the pressure is below two or three atmospheres. When the operation is over the outlet tube can be withdrawn and keyhole stopped.

It is preferable to allow the formaldehyde gas to remain as long as possible, but from three to four hours' contact is sufficient for a good disinfection. Afterward it is necessary to air the apartment. To do this, enter rapidly, wearing the glasses and, without breathing, open the window. One half hour later, one can without inconvenience enter the room. The order of formaldehyde can be neutralized more rapidly by injecting a little ammonia into the room.

After the apparatus is cooled remove the thermometer, take off the cover of the autoclave, and empty the residue, which should be in a liquid form. Clean with water and dry with a linen rag.

It will be seen from the experiment that the organisms protected by the folds of blanket were not killed, and this brings up another consideration, namely, that of penetration. No matter how valuable this agent in a free state may be as a disinfectant of superficially infected areas, such as walls, floors, and ceilings, it must be admitted that its

FORMALDEHYDE DISINFECTION.—EXPERIMENT No. 1  
*Cubical Contents of Room, 1,165 Feet. Amount of Formochloral, 1,250 c. c. Exposure, Four Hours.*  
 May 27, 1897.

NAME OF ORGANISM.	Method of preparation and exposure.	Place located.	Time of exposure.*	Result.
B. typhosus.....	Dried on silk threads and inclosed in sterile paper.	Shelf, 4 feet high.	4 hours.	No growth.
B. typhosus.....	"	Sink, 3½ feet high.	4 hours.	
B. diptheriæ.....	"	"	4 hours.	
Staph. pyogenes aureus.	"	Coat hooks, 6½ ft. high.	4 hours.	
B. anthracis.....	"	Shelf by window.	4 hours.	
B. diptheriæ.....	"	Table by window.	4 hours.	
B. diptheriæ.....	" paper-covered dish.	Table by sink.	4 hours.	
B. typhosus.....	"	On the floor.	4 hours.	
B. anthracis.....	"	On chair, center room.	4 hours.	Growth.
B. anthracis (spores)...	" sterile paper.	"	4 hours.	
B. diptheriæ.....	" blanket.	"	4 hours.	
B. typhosus.....	"	"	4 hours.	
B. anthracis (spores)...	" paper.	"	4 hours.	
Staph. pyogenes aureus.	" paper-covered dish.	On the floor.	4 hours.	
Staph. pyogenes aureus.	"			No damaged goods.

\* Time taken from the turning on of the gas.

power of penetration is not great, and although somewhat foreign to the subject of this paper, I will describe some experiments which were made to test this matter of penetration. These were made at the City Disinfecting Station by R. B. F. Randolph, assistant bacteriologist.

TABLE 1

No.	Culture.	Location.	Result.
1	Anthrax.....	Inside a straw mattress.	Lived.
2	".....	" " " "	"
3	Typhoid.....	" " " "	"
4	S. P. A.....	" " " "	"
5	Anthrax.....	Folded in the middle of an excelsior mattress.	"
6	Diphtheria...	" " " "	"
7	S. P. A.....	" " " "	"
8	Typhoid.....	" " " "	"
9	Anthrax.....	Between mattress and feather bed.	"
10	Diphtheria...	" " " "	"
11	S. P. A.....	" " " "	"
12	Typhoid.....	" " " "	"
13	Anthrax.....	Surrounded by two layers of blankets.	"
14	Diphtheria...	" " " "	"
15	S. P. A.....	" " " "	"
16	Typhoid.....	" " " "	"
17	Anthrax.....	" " one layer of blanket.	"
18	Diphtheria...	" " " "	Died.
19	S. P. A.....	" " " "	"
20	Typhoid.....	" " " "	"
21	Anthrax.....	" " four layers of blankets.	Lived.
22	Diphtheria...	" " " "	Died.
23	S. P. A.....	" " " "	"
24	Typhoid.....	" " " "	"
25	Anthrax.....	" " eight " "	Lived.
26	Diphtheria...	" " " "	Died.
27	S. P. A.....	" " " "	Lived.
28	Typhoid.....	" " " "	Died.
29	Anthrax.....	Exposed on top of the pile of goods.	"

EXPERIMENT No. 2

A Trillat autoclave was so arranged that a stream of formaldehyde gas could be forced into the inner chamber of the disinfecting oven. Sterile silk threads were immersed in cultures of sporulating anthrax, *B. typhosus*, *B. diphtheriæ*, and *staphylococcus pyogenes aureus*, and allowed to dry at ordinary temperatures. When dry they were inclosed in sterile filter-paper envelopes and arranged as described in Table 1.

The conditions of the experiment were as follows :

Quantity of formochloral used, 1,250 c. c.

Capacity of the chamber, 340 cubic feet.

Vacuum at the beginning of the test, 14 inches of mercury.

Vacuum after the admission of the formaldehyde, 11 inches.

Gas was run in for thirty minutes.

After the gas had ceased to flow, air was admitted until the gauge stood at zero.

One hour after the gas was shut off the chamber was twice exhausted and filled with air.

The chamber was opened at 10 A. M. the following day.

There was a slight odor of formaldehyde, but not enough to prevent a man from going in immediately. About two gallons of water smelling strongly of the gas was found on the floor of the chamber. The goods were dry and uninjured.

It will be seen that the disinfection was far from complete, the anthrax not being killed except in one instance, and the other organisms in the more protected portions of the pile not being affected. This lack of penetration, however, can be partially accounted for. The air admitted to the chamber immediately after the gas was shut off was taken through the sewer outlet, and in doing this the contents of the trap were sucked up into the chamber and possibly dissolved, and thus rendered inoperative a large amount of the gas.

It was thought that a greater and more uniform degree of penetration could be secured by slightly heating the chamber, inasmuch as the diffusion power of a gas is largely influenced by its temperature. The following experiment was therefore made:

The formaldehyde was generated in an autoclave built for that purpose by the Kny-Scheerer Co. It consisted of a copper boiler nicked inside and out and provided with a water gauge, safety valve, thermometer, and exit tubes for the gas evolved. Heat was produced by a triple "Prismus" oil burner. The apparatus was connected with the disinfecting chamber by a rubber tube which connected with a small iron pipe entering the chamber at the top. The formaldehyde was generated from a mixture of Kny-Scheerer formalin 38.7 per cent of  $\text{CH}_2\text{O}$ . The mixture was made up as follows:

Formalin.....	1,350 c. c.
Calcium chloride (anhydrous).....	200 grs.
Water to make up to.....	4,000 c. c.



The determination of formaldehyde was made by the ammonia method as given by Struver (*Zeit. f. Hyg., Bd. xxv, Heft 2*).

All determinations were made in duplicate by both gravimetric and volumetric methods. It would have been advisable to determine the amount of methyl alcohol in the formalin, as this reacts with formaldehyde at the temperature of the operation, giving methylal, a substance having little or no disinfecting action. Any methyl alcohol present, therefore, diminishes the efficiency of the formalin. No satisfactory method of determining methyl alcohol in such a mixture has yet been devised, and the results of this experiment are therefore subject to a correction on this account. We have been assured by the manufacturer of the formalin used, however, that it contains less than one per cent of methyl alcohol, and no serious error will be made by neglecting it.

Silk threads were soaked for several hours in twenty-four-hour cultures of the bacteria used, and dried at room temperatures. These threads were then inclosed in sterile filter-paper envelopes as in the previous experiment, and were arranged as shown in Table 2, which also shows the result of the experiment.

TABLE 2

Organism used.	Location.	Result.
Diphtheria .....	Within a folded mattress.	Killed.
Typhoid .....	" " "	"
Anthrax spores .....	" " "	"
Staph. pyogenes aureus .....	" " "	"
Diphtheria .....	In the middle of a folded blanket.	"
Typhoid .....	" " " "	"
Anthrax spores .....	" " " "	"
Staph. pyogenes aureus .....	" " " "	"
Diphtheria .....	Between two folded blankets.	"
Typhoid .....	" " "	"
Anthrax spores .....	" " "	"
Staph. pyogenes aureus .....	" " "	"
Diphtheria .....	Exposed on top of pile.	"
Typhoid .....	" " "	"
Anthrax spores .....	" " "	"
Staph. pyogenes aureus .....	" " "	"

The pile of material was placed on the truck and run into the oven, being as nearly as possible in the center of the chamber. The doors were then tightly closed and



the vacuum pump started, and steam turned into the outer jacket in order to heat the inner chamber. In thirty minutes a vacuum of 14.25 inches was obtained, and the temperature of the inner chamber was then 40° C. In the meantime the lamp under the autoclave had been lighted, and the pressure raised to 37.5 pounds. The valves were then opened and the formaldehyde gas admitted to the chamber, the pressure of the autoclave being kept above 30 pounds. The gas was allowed to flow thirty minutes and was then shut off, the vacuum in the chamber having fallen to 10 inches and the temperature risen to 49° C. Air was then admitted to the chamber through the safety valve until the vacuum was reduced to zero. The temperature of the inner chamber was then raised to 65° C. and kept there during the rest of the experiment, which lasted altogether an hour and a half. At the expiration of this time the chamber was opened, the threads in the envelopes were removed and taken to the laboratory, where they were planted in sterile broth and incubated for a week. No moist cultures were used, as it was intended to make the experiment correspond as closely as possible to actual working conditions, and in practice we are seldom called upon to disinfect articles that are not dry. The formalin mixture remaining in the autoclave was carefully removed and measured. It amounted to 2,300 c. c. and contained 9.27 per cent of formaldehyde, corresponding to 213.2 grammes. As the original mixture contained 500 grammes 286.8 were present in the chamber, and as the capacity of the chamber is 10,188 cubic metres, each cubic metre contains 28.11 grammes of  $\text{CH}_2\text{O}$ . This corresponds to a volume per cent of 1.93, or, in round numbers, two per cent.

This experiment proves that, under the conditions adopted, two per cent is sufficient to disinfect anthrax spores in the middle of a mattress—a very severe test—and, on this account, it is recommended that two per cent be the minimum of gas allowed. As regards the temperature and the vacuum, the experiment shows that a temperature of 65° C. is high enough, and that a vacuum of at least half an atmosphere is desirable.

It will be seen that the temperature exercises a marked effect on the disinfection, and the failure of the first experi-

ment, where a much larger percentage of gas was used, must be attributed to the low temperature at which it was conducted.

This method, therefore, gives a convenient and satisfactory disinfection of goods that would certainly be injured, if not ruined, by the use of steam.

The advantages of the autoclave over the lamps are at once apparent:

First. It produces a large volume of the gas.

Second. Rapidity of application.

Third. It is constantly under observation and located outside the room.

Fourth. No damage to disinfected goods.

#### CLEANLINESS IN THE CARE OF PATIENTS AND SICK ROOMS

The older methods of disposing of soiled clothing, dressings, and discharges were most objectionable. Old foul dressings were carried from the halls, some of them to the laundry, to be washed and used again. Excrements were carried in open vessels to the closets, deposited there, and in the best-regulated hospitals or homes some disinfectant poured down the closet every time it was used, or several times a day, and the results were easily to be imagined.

The methods pursued at the present time in my practice are to place all soiled dressings directly on their removal into a vessel. The vessel is closed with an air-tight rubber cover and taken away and the dressings at once cremated. The vessel is disinfected at once, and made ready for further use. Vessels used for the reception of excrement, urinals included, receive before using some disinfectant and deodorizer, and when used are covered with air-tight rubber covers and taken away. Wash basins are emptied into slop pails that can be closed with rubber covers while conveying them to the closets to be emptied and cleansed.

Bed linen is placed in a clean bag of rubber cloth and conveyed to the laundry. In this way the halls, stairways, and elevator are kept free from contamination and mal-odors.



## INDEX

- Abdominal incision, hæmorrhage, 30.  
Abscess, pelvic, 85.  
Acetic acid, 104.  
Adenomectomy, 97, 100.  
Adhesions, not possible, 25.  
    of appendix vermiformis, 32.  
    of bladder, 34.  
    of intestines, 33, 52.  
    of omentum, 31, 52.  
    of rectum, 34.  
    recent, 35.  
    vascular, old, 55.  
Advantages of method, 25, 83, 134.  
Anæsthesia, 64, 77, 119.  
Angioma, 115, 132.  
    of urethra, 113.  
Antisepsis and asepsis, 136 *et seq.*  
Appendectomy, 57.  
Appendix vermiformis, adhesions, 32.  
    treatment, 23.  
Artery, treatment, 23.  
    treatment of isolated, 18.  
Aspiration of Fallopian tube, 56.
- Battery outfits, 14 *et seq.*  
Belladonna tr., 124.  
Bichloride of mercury, 77.  
Bismuth subgallate, 124.  
Bladder, adhesions, 34.  
    tumors, 102.  
    ulcer, 110, 118.
- Cancer, of uterus, 65.  
    of cervix, 65, 69.  
    of bladder, 106.  
    cures, 83.  
Carbolic acid, 77.  
Carbuncle, 93.  
Caruncle, 113.
- Case histories—appendectomy, 60.  
    bladder, neoplasm, 107.  
    epithelioma of lip, 129.  
    Fallopian tube, patency, 49, 51.  
    fissura in ano, 128.  
    mammectomy, 3, 97, 99.  
    migrated ligature, 7, 51.  
    nævus, 129.  
    nævus pilaris, 129.  
    ovariotomy, 50, 51.  
    post-mortem condition of stump, 6.  
Catgut ligatures, objection to, 1, 25, 96.  
    for peritoneum, 83.  
Cautics, 131.  
Cautery, galvano, 129.  
    knife, 72, 78.  
    loop, 69.  
Cervix, amputation, 45.  
Clamp, ovariotomy, 35.  
    hæmorrhoidal, 121.  
Coagulation necrosis, 27, 29.  
Cocaine, 127.  
Current, strength of, 10, 13, 26, 130.  
    length of time to be maintained,  
        18.  
Cystotomy, 102.  
Cysts, labial, 87.  
    vaginal, 88.
- Directions for use of instruments, 12.  
Dome electrode, 75.  
    point, 32, 41, 55.  
Doors, sanitary construction, 149.  
Drainage in pelvic abscess, 86.  
Dressings, disposal of soiled, 169.  
Dry dissector, 40.
- Electrolysis, 130.  
Endoscope, glass, 118, 127.

- Epithelioma of cervix, 69.  
of skin, 132.  
Experiments, 23, 26, 29.  
Experimental results, 21, 25, 29.
- Fallopian tube, experiments, 26, 29.  
patency, 6, 49, 51, 59.  
operation upon, 49.  
aspiration, 56.
- Fibroid, 39 *et seq.*  
Fissure of anus, 125.  
Fissure of neck of bladder, 118.  
Fistula of rectum, 57.  
Flaxseed tea enema, 124, 125.  
Floors, sanitary construction, 140.  
Forceps, plain, 9.  
hæmorrhoidal, 121.  
for ovariectomy, 35.  
shield, laparotomy, 34.  
elytrotomy, 80.  
the dome, 32.  
temperature required, 35.  
time required, 18.
- Formaldehyde disinfection, 160 *et seq.*  
French method for hysterectomy, 82, 84.  
Friable tissue, 25, 132.
- Galvano-cautery, 67, 129.  
Glands, lymphatic, 100.  
of urethra, 116.  
Glycerin and carbolic for hands, 59.  
Glycerrhiza comp. ext., 124.
- Healing process, 23, 30, 107.  
Heat, 10, 104, 152.  
Hæmatocele, pudental, 92.  
Hæmorrhage in abdominal section, 30.  
capillary, 32.  
control of, 25.  
in sac of Douglas, 32.  
secondary, 18.  
with cautery knife, 73, 131.  
Hæmorrhoidal clamp, 121.  
Hæmorrhoids, 120.  
Hernia, 30.  
High amputation of cervix, 71.  
Hospital construction, 137 *et seq.*  
Hydrosalpinx, 52.  
Hysterectomy, advantage of method, 83.  
for cancer, abdominal, 65.  
vaginal, 76.  
for fibroid, 42.  
mortality, 84.
- Instruments, sterilization, 158.  
Intestine, adhesions, 33.  
protection to, 31.  
operation upon, 23, 57.
- Labial cysts, 87.  
Laboratory experiments, 21, 23.  
Ligature, objections to, 1, 25, 30, 32, 49.  
Lymphatics, treatment, 25.
- Mammectomy, 95.  
Mesosalpinx treatment, 54.  
Mortality of method, 84.  
Mucous surfaces, treatment, 23, 25, 57.  
Myomectomy, 39.
- Neoplasms, bladder, 102.  
of mucous membranes and skin, 129.  
Nerves are devitalized, 25.
- Omentum, adhesions, 32, 52.  
treatment, 31.  
Opii comp. liq., 124.  
Ovariectomy, 30.  
Ovario-salpingectomy, 52.
- Pain, 5, 25, 97, 133.  
Pedicle, formation, 53.  
forceps, small, 35.  
large, 36, 37.  
post-operationem, 5.  
repair, 23.  
treatment, 35 *et seq.*  
Pelvic abscess, 85.  
Peritoneum, 37, 45, 72.  
suturing of, 83.  
Plumbing, sanitary, 149.  
Preparatory treatment, hæmorrhoids,  
120.  
major operations, 156.  
Pudental wounds, 90.  
Pyosalpinx, 54.
- Reparative process, 23, 25, 59, 64, 107,  
122.  
with ligature, 5.  
Recoveries incomplete with ligature, 49,  
50.  
Rheostat, 12.
- Salpingectomy, 49.  
Septic processes inhibited, 25, 60.  
Sequelæ, operative, unfavorable, 5.

- Shield forceps, 40, 80.  
 Silk ligatures post-operationem, 5.  
 Sloughing from pressure, 44.  
 Soda bicarbonate, 124.  
 Speculum, Byrne's, 68.  
 Sterilizing effect of method, 25.  
 Stump ablation, 53.  
   aseptic conditions, 25.  
   exudates, with ligature, 50, 59, 60.  
   ligation, 6.  
   conditions after treatment, 19, 63.  
   size after treatment, 25.  
   reparatory processes, 25.  
 Suture material, 158.
- Temperature of heated forceps, 12.  
 Time necessary for desiccation, 18, 31,  
   81, 96, 121.  
 Transformer, 11.
- Ulcer of bladder, 110, 118.  
   of rectum, 125.
- Ureter, treatment, 23.  
 Urethra, glands of, 116.  
   papilloma of, 117.  
   stenosis of, 117.
- Vagina, cysts of, 88.  
   disinfection of, 76.  
   hysterectomy through, 76.  
   indications for section of, 85.  
 Varix of vulva, 89.  
 Vascular tumors, 130.  
 Vaseline for forceps, 13, 36.  
 Ventilation, sterile, methods of, 152.  
 Vessels, treatment of, in hysterectomy,  
   43.  
 Volsellum forceps diverging, 72.  
 Voltage required, 11.  
 Vulva, diseases of, 85.
- Walls, sanitary construction, 139.  
 Watts required, 10.  
 Windows, sanitary construction, 143.

## LIST OF AUTHORS CITED

- Armstrong, 57.  
 Barker, 100.  
 Beard, 135.  
 Bloom, 131.  
 Bovee, 51.  
 Byrne, 65, 135.  
 Chrobak, 50.  
 Clark, 65.  
 Dickinson, 123.  
 Emery, 137.  
 Ferguson, 6.  
 Haggard, 55.
- Keith, 7, 49.  
 Kelly, 4, 47, 65.  
 Pignolet, 8.  
 Randolph, 165.  
 Ries, 49.  
 Routh, 88.  
 Schauta, 50.  
 Schleich, 64.  
 Seymour, 23.  
 Smith, 57.  
 Van Buren, 125.  
 Wilson, 160.

THE END